

CHASSIS SECTION

This service manual has been prepared to provide SUBARU service personnel with the necessary information and data for the correct maintenance and repair of SUBARU vehicles.

This manual includes the procedures for maintenance, disassembling, reassembling, inspection and adjustment of components and diagnostics for guidance of experienced mechanics.

Please peruse and utilize this manual fully to ensure complete repair work for satisfying our customers by keeping their vehicle in optimum condition. When replacement of parts during repair work is needed, be sure to use SUBARU genuine parts.

All information, illustration and specifications contained in this manual are based on the latest product information available at the time of publication approval.

FRONT SUSPENSION	FS
REAR SUSPENSION	RS
WHEEL AND TIRE SYSTEM	WT
DIFFERENTIALS	DI
TRANSFER CASE	TC
DRIVE SHAFT SYSTEM	DS
ABS	ABS
ABS (DIAGNOSTICS)	ABS(diag)
VEHICLE DYNAMICS CONTROL (VDC)	VDC
VEHICLE DYNAMICS CONTROL (VDC) (DIAGNOSTICS)	VDC(diag)
BRAKE	BR
PARKING BRAKE	PB
POWER ASSISTED SYSTEM (POWER STEERING)	PS

POWER ASSISTED SYSTEM (POWER STEERING)

PS

	Page
1. General Description	2
2. Steering Wheel.....	20
3. Universal Joint.....	21
4. Tilt Steering Column.....	23
5. Steering Gearbox [LHD Model]	25
6. Steering Gearbox [RHD Model]	46
7. Pipe Assembly [LHD Model]	65
8. Pipe Assembly [RHD Model].....	71
9. Oil Pump	77
10. Reservoir Tank.....	83
11. Power Steering Fluid.....	84
12. General Diagnostic Table.....	85

General Description

POWER ASSISTED SYSTEM (POWER STEERING)

1. General Description

A: SPECIFICATION

Model		Non-turbo (Except for 3.0 R)	Turbo	3.0 R
Whole system	Minimum turning radius	m (ft) 5.4 (17.8)		
	Steering angle (Inside — outside)	2.0 i, 2.5 i: 37.3° — 33.0°, 2.0 GT, 3.0 R: 37.2° — 32.9°, OUTBACK: 37.8° — 33.5°		
	Steering wheel diameter	mm (in) 375 (14.76)		
	Overall gear ratio (Turns, lock to lock Gearbox)	3.2	2.8	
Gearbox	Type	Rack and Pinion, Integral		
	Backlash	0 (Automatically adjustable)		
	Valve (Power steering system)	Rotary valve		
Pump (Power steering system)	Type	Vane pump		
	Oil tank	Installed on body		
	Specific output	cm ³ (cu in)/rev. 7.2 (0.439)	8.5 (0.519)	9.6 (0.586)
	Relief pressure	kPa (kg/cm ² , psi) 6,767 — 7,453 (69 — 76, 981 — 1,081)	7,350 — 8,036 (75 — 82, 1,067 — 1,165)	8,300 — 9,000 (85 — 92, 1,204 — 1,305)
	Hydraulic fluid control	Dropping in response to increased engine revolutions		
	Hydraulic fluid	ℓ (US qt, Imp qt) 1,000 rpm: 6.5 (6.9, 5.7) 3,000 rpm: 5 (5.3, 4.4)	1,000 rpm: 6.15 (6.5, 5.4) 3,000 rpm: 5.5 (5.8, 4.8)	1,000 rpm: 6.5 (6.9, 5.7) 3,000 rpm: 5.5 (5.8, 4.8)
	Range of revolution	rpm 680 — 9,800	680 — 9,600	
	Revolving direction	Clockwise		
Working fluid (Power steering system)	Fluid	ATF DEXRON III or equivalent		
	Capacity	Oil tank	ℓ (US qt, Imp qt) 0.2 (0.2, 0.2)	
		Whole system	0.7 (0.7, 0.6)	

General Description

POWER ASSISTED SYSTEM (POWER STEERING)

Steering wheel	Free play	mm (in)	17 (0.67)	
Steering angle	Inner wheel		2.0 i, 2.5 i: 37.3°±1.5°, 2.0 GT, 3.0 R: 37.2°±1.5°, OUTBACK: 37.8°±1.5°	
	Outer wheel		2.0 i, 2.5 i: 33.0°±1.5°, 2.0 GT, 3.0 R: 32.9°±1.5°, OUTBACK: 33.5°±1.5°	
Steering shaft	Clearance between steering wheel and column cover	mm (in)	3.0 (0.12)	
Steering gearbox (Power steering system)	Sliding resistance	N (kgf, lb)	314 (32, 71) or less Difference between right and left sliding resistance: Less than 20%	
	Rack shaft play in radial direction	Right-turn steering	mm (in)	LHD 0.3 (0.16) or less
				RHD Horizontal movement: 0.6 (0.024) or less Vertical movement: 0.4 (0.016) or less
		Left-turn steering	mm (in)	LHD Horizontal movement: 0.6 (0.024) or less Vertical movement: 0.4 (0.016) or less
				RHD 0.3 (0.16) or less
	Input shaft play	In radial direction	mm (in)	0.18 (0.0071) or less
		In axial direction	mm (in)	0.27 (0.0106) or less
Resistance to rotation	N (kgf, lb)	Maximum allowable value: 13 (1.3, 2.9) or less Difference between right and left sliding resistance: Less than 20%		
Oil pump (Power steering system)	Pulley shaft	Radial play	mm (in) 0.4 (0.016) or less	
		Axial play	mm (in) 0.9 (0.035) or less	
	Pulley	Ditch deflection	mm (in) 1.0 (0.039) or less	
		Resistance to rotation	N (kgf, lb) 9.22 (0.94, 2.07) or less	
	Regular pressure (Unloaded)kPa (kg/cm ² , psi)		981 (10, 142) or less	
Steering wheel effort (Power steering system)	At standstill with engine idling on a concrete road	N (kgf, lb)	29.4 (3.0, 6.6) or less	
	At standstill with engine stalled on a concrete road	N (kgf, lb)	294.2 (30, 66.2) or less	

Recommended power steering fluid	Manufacturer
ATF DEXRON III or equivalent	B.P.
	CALTEX
	CASTROL
	MOBIL
	SHELL
	TAXACO

General Description

POWER ASSISTED SYSTEM (POWER STEERING)

B: COMPONENT

1. STEERING WHEEL AND COLUMN

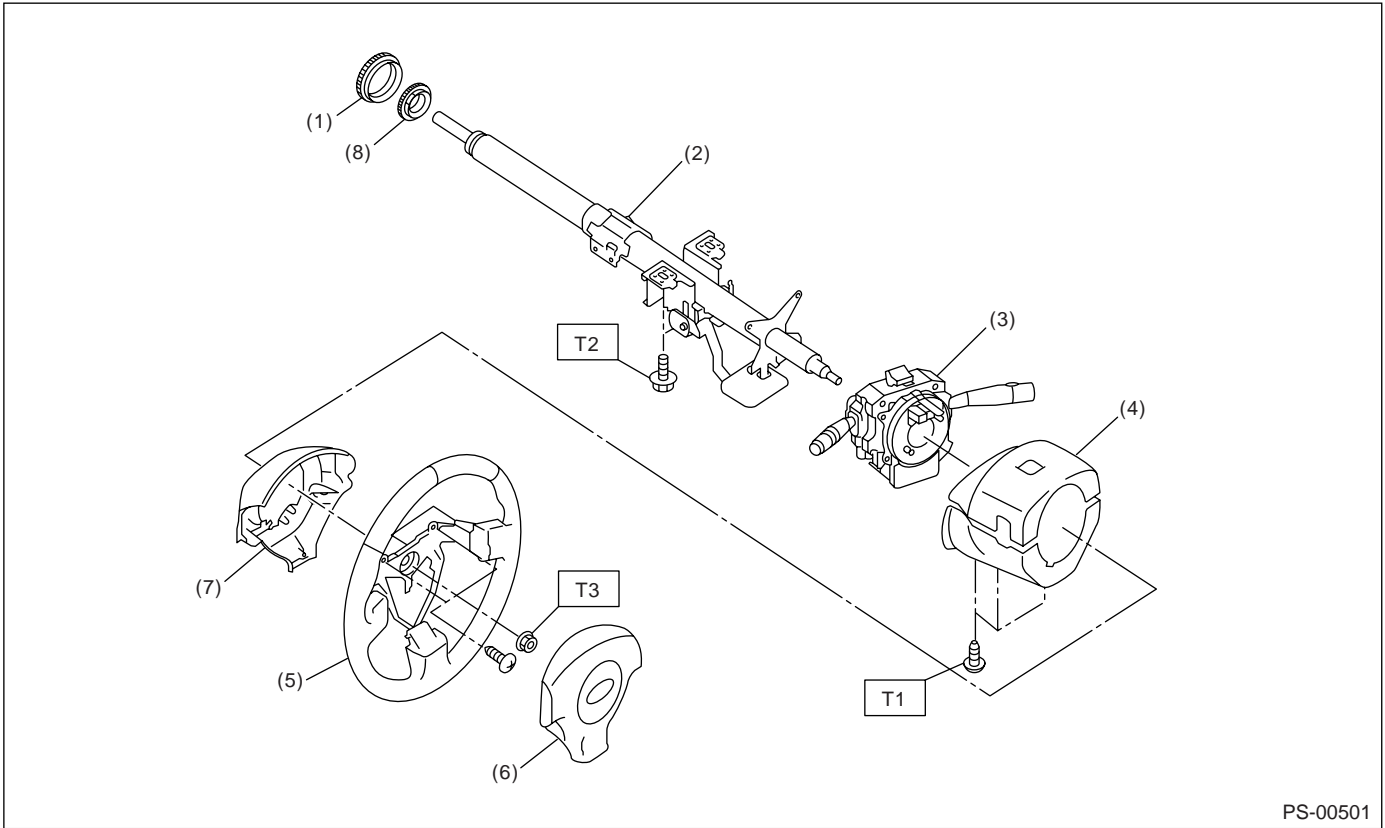

- | | |
|-----------------------------|--------------------------------|
| (1) Bushing | (5) Steering wheel |
| (2) Steering shaft | (6) Airbag module |
| (3) Steering roll connector | (7) Steering wheel lower cover |
| (4) Column cover | (8) Insulator |

Tightening torque: N·m (kgf·m, ft·lb)

T1: 1.2 (0.12, 0.9)

T2: 25 (2.5, 18.1)

T3: 45 (4.6, 33.2)

General Description

POWER ASSISTED SYSTEM (POWER STEERING)

2. POWER ASSISTED SYSTEM

- Hose and tank

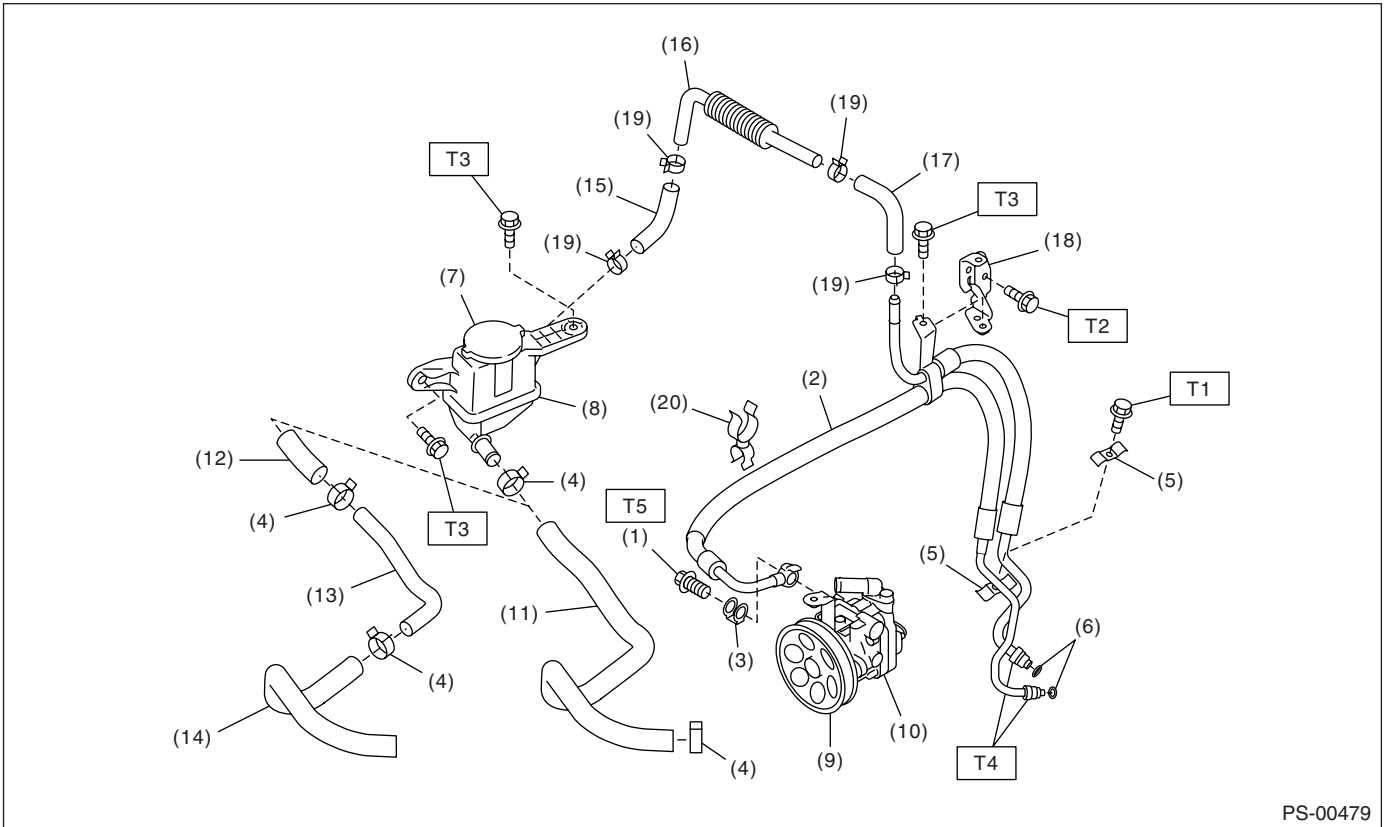

PS-00479

- | | |
|---------------------|-------------------------------------|
| (1) Eye bolt | (10) Oil pump |
| (2) Hose | (11) Suction hose (Non-turbo model) |
| (3) Eye bolt gasket | (12) Suction hose (Turbo model) |
| (4) Clip | (13) Suction hose (Turbo model) |
| (5) Clamp E | (14) Suction hose (Turbo model) |
| (6) O-ring | (15) Return hose |
| (7) Cap | (16) Oil cooler |
| (8) Reservoir tank | (17) Return hose |
| (9) Pulley | (18) Hose bracket |

- | |
|-----------|
| (19) Clip |
| (20) Clip |

Tightening torque: N·m (kgf·m, ft·lb)

- | |
|------------------------------|
| T1: 7.4 (0.75, 5.4) |
| T2: 17.6 (1.79, 13.0) |
| T3: 12.7 (1.30, 9.4) |
| T4: 15 (1.5, 10.8) |
| T5: 39.2 (4.0, 28.9) |
-

General Description

POWER ASSISTED SYSTEM (POWER STEERING)

- Gearbox (LHD model)

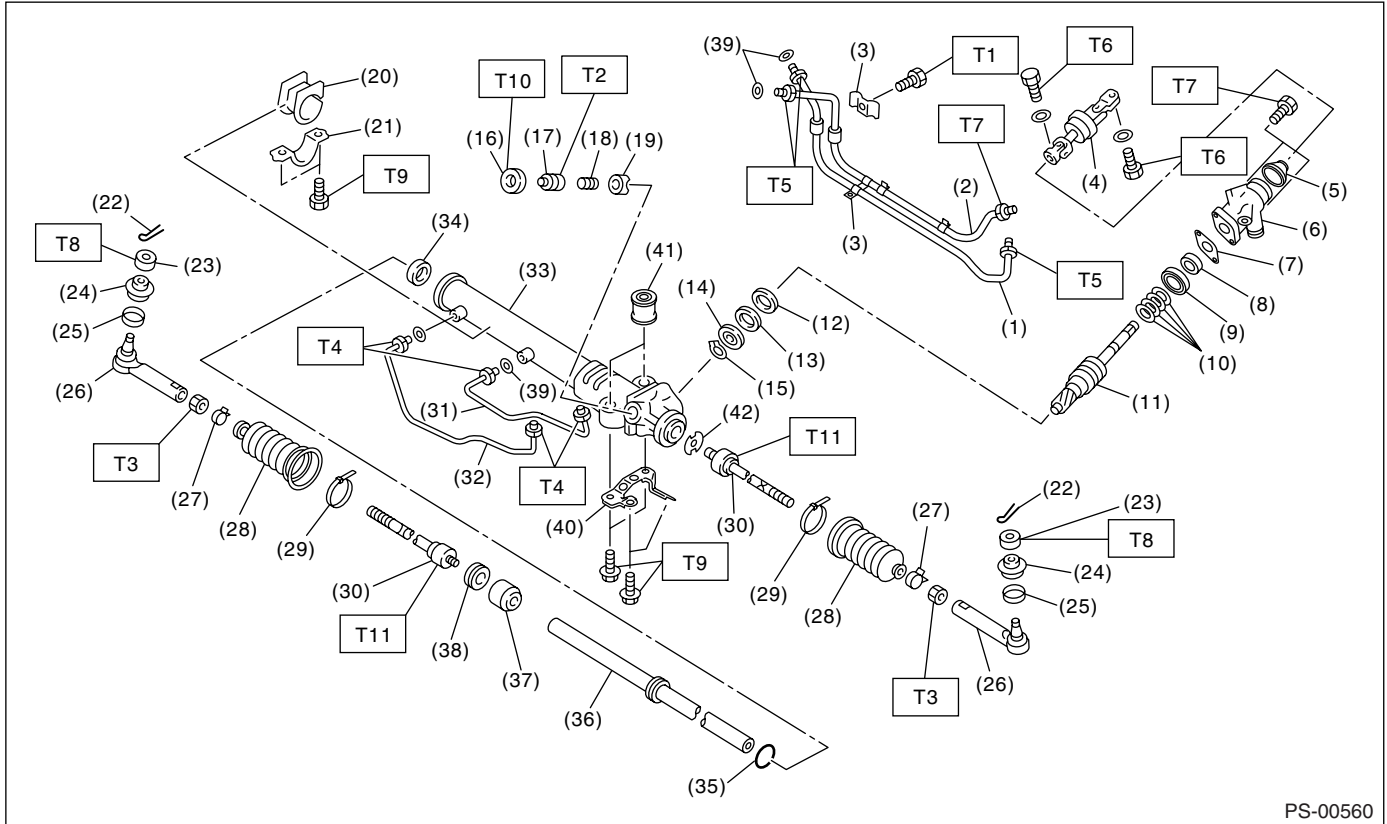

PS-00560

- | | | |
|--------------------------|--------------------|------------------|
| (1) Pipe C | (20) Adapter | (39) O-ring |
| (2) Pipe D | (21) Clamp | (40) Bracket |
| (3) Clamp plate | (22) Cotter pin | (41) Bushing |
| (4) Universal joint | (23) Castle nut | (42) Lock washer |
| (5) Dust seal | (24) Dust cover | |
| (6) Valve housing | (25) Clip | |
| (7) Gasket | (26) Tie-rod end | |
| (8) Oil seal | (27) Clip | |
| (9) Bushing | (28) Boot | |
| (10) Seal ring | (29) Band | |
| (11) Pinion & valve ASSY | (30) Tie-rod | |
| (12) Oil seal | (31) Pipe B | |
| (13) Back-up washer | (32) Pipe A | |
| (14) Ball bearing | (33) Steering body | |
| (15) Snap ring | (34) Oil seal | |
| (16) Lock nut | (35) Piston ring | |
| (17) Adjusting screw | (36) Rack | |
| (18) Spring | (37) Rack bushing | |
| (19) Sleeve | (38) Holder | |

Tightening torque: N-m (kgf-m, ft-lb)

- | | |
|-------------|------------------------|
| T1: | 6 (0.6, 4.3) |
| T2: | 7.4 (0.75, 5.4) |
| T3: | 85 (8.6, 62.2) |
| T4: | 13 (1.3, 9.4) |
| T5: | 15 (1.5, 10.8) |
| T6: | 24 (2.4, 17.4) |
| T7: | 25 (2.5, 18.1) |
| T8: | 27 (2.75, 19.9) |
| T9: | 60 (6.1, 44.1) |
| T10: | 39 (4.0, 28.9) |
| T11: | 78 (8.0, 57.9) |

General Description

POWER ASSISTED SYSTEM (POWER STEERING)

• Gearbox (RHD model)

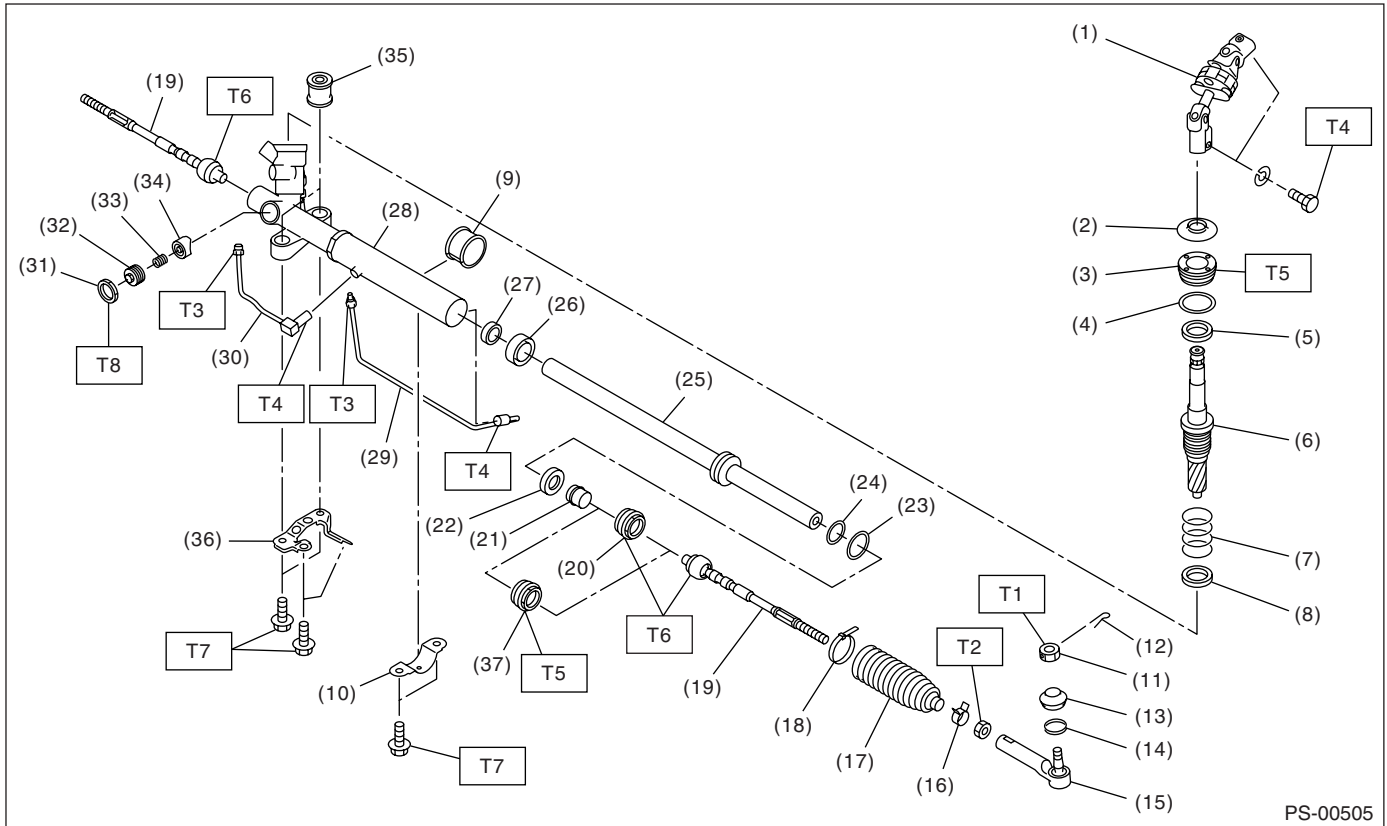

(1) Universal joint	(17) Boot	(33) Spring
(2) Dust cover	(18) Band	(34) Sleeve
(3) Plug	(19) Tie-rod	(35) Bushing
(4) O-ring	(20) Holder (Turbo, 3.0 R model)	(36) Bracket
(5) Oil seal	(21) Bushing	(37) Holder (Except for turbo, 3.0 R model)
(6) Control valve	(22) Oil seal	
(7) Seal ring	(23) Oil seal	
(8) Oil seal	(24) O-ring	
(9) Adapter	(25) Rack	
(10) Clamp	(26) Oil seal	
(11) Castle nut	(27) Back-up washer	
(12) Cotter pin	(28) Steering body	
(13) Dust seal	(29) Pipe A	
(14) Clip	(30) Pipe B	
(15) Tie-rod end	(31) Lock nut	
(16) Clip	(32) Adjusting screw	

Tightening torque: N·m (kgf·m, ft·lb)

T1: 27 (2.75, 19.9)

T2: 85 (8.6, 62.2)

T3: 20 (2.0, 14.5)

T4: 24 (2.4, 17.4)

T5: 64 (6.5, 47.0)

T6: 90 (9.0, 65.1)

T7: 60 (6.1, 44.1)

T8: 39 (4.0, 28.9)

General Description

POWER ASSISTED SYSTEM (POWER STEERING)

3. OIL PUMP

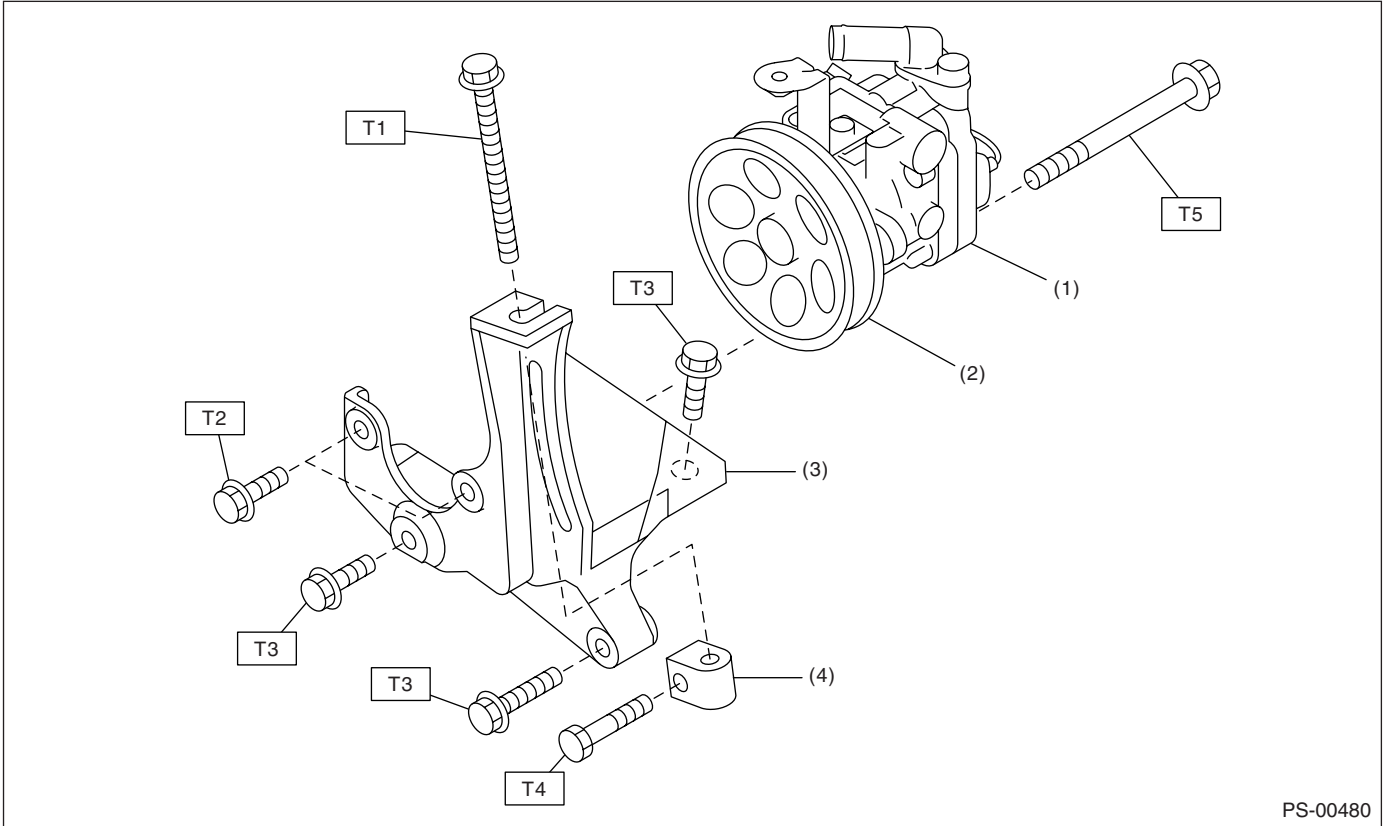

- (1) Oil pump
- (2) Pulley
- (3) Bracket
- (4) Belt tension nut

Tightening torque: N·m (kgf·m, ft·lb)

T1: 8 (0.8, 5.8)

T2: 15.7 (1.6, 11.6)

T3: 22 (2.2, 15.9)

T4: 25 (2.5, 18.1)

T5: 37.3 (3.8, 27.5)

C: CAUTION

- Wear work clothing, including a cap, protective goggles and protective shoes during operation.
- Before removal, installation or disassembly, be sure to clarify the failure. Avoid unnecessary removal, installation, disassembly and replacement.
- Be careful not to burn yourself, because each part on the vehicle is hot after running.
- Use SUBARU genuine power steering fluid, grease etc. or the equivalent. Do not mix fluid, grease etc. with that of another grade or from other manufacturers.
- Be sure to tighten fasteners including bolts and nuts to the specified torque.
- Place shop jacks or rigid racks at the specified points.
- Before securing a part on a vise, place cushioning material such as wooden blocks, aluminum plate or cloth between the part and the vise.

General Description

POWER ASSISTED SYSTEM (POWER STEERING)

D: PREPARATION TOOL

1. SPECIAL TOOL

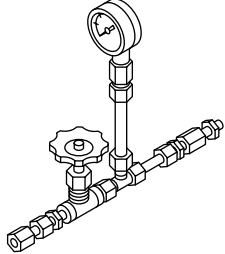
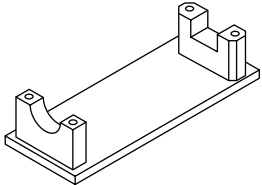
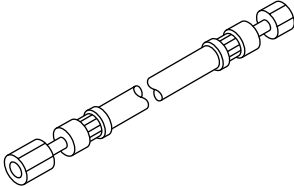
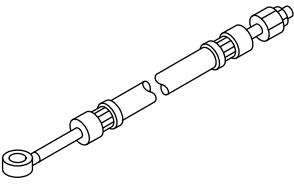
ILLUSTRATION	TOOL NUMBER	DESCRIPTION	REMARKS
 <p style="text-align: center;">ST-925711000</p>	925711000	PRESSURE GAUGE	Used for measuring oil pump pressure.
 <p style="text-align: center;">ST-926200000</p>	926200000	STAND	<ul style="list-style-type: none"> • Used when inspecting characteristic of gear-box assembly and disassembling it. • Used with BOSS D (34199AG000).
 <p style="text-align: center;">ST34099AC010</p>	34099AC010	ADAPTER HOSE A	Used with PRESSURE GAUGE (925711000).
 <p style="text-align: center;">ST34099AC020</p>	34099AC020	ADAPTER HOSE B	Used with PRESSURE GAUGE (925711000).

General Description

POWER ASSISTED SYSTEM (POWER STEERING)

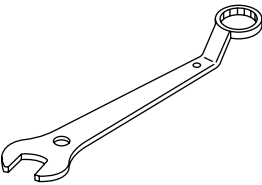
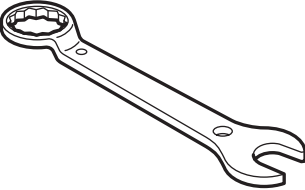
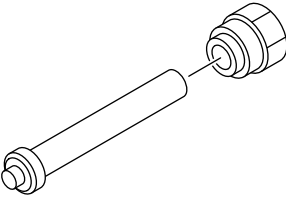
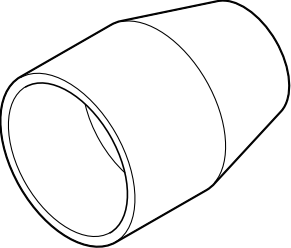
ILLUSTRATION	TOOL NUMBER	DESCRIPTION	REMARKS
 <p style="text-align: center;">ST-926230000</p>	926230000	SPANNER	For the lock nut when adjusting backlash of gear-box.
 <p style="text-align: center;">ST34099PA100</p>	34099PA100	SPANNER	Used when measuring the rotating resistance of gearbox assembly.
 <p style="text-align: center;">ST-926420000</p>	926420000	PLUG	When fluid leaks from pinion side of gearbox assembly, remove pipe B from valve housing, attach this tool and check fluid leaking points.
 <p style="text-align: center;">ST-926250000</p>	926250000	GUIDE	<ul style="list-style-type: none"> • Used for installing holder assembly into rack housing. • Except for turbo and 3.0 R model.

General Description

POWER ASSISTED SYSTEM (POWER STEERING)

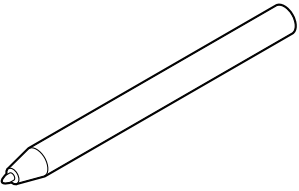
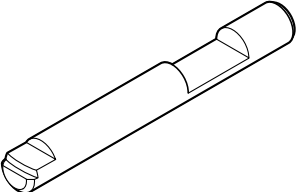
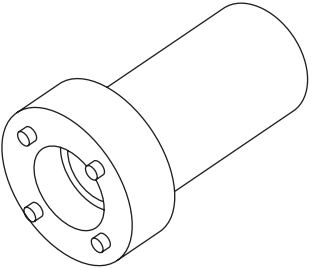
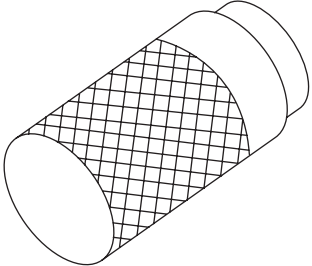
ILLUSTRATION	TOOL NUMBER	DESCRIPTION	REMARKS
 <p style="text-align: center;">ST34099FA060</p>	34099FA060	PUNCH HOLDER	Used for caulking.
 <p style="text-align: center;">ST34099FA080</p>	34099FA080	PUNCH	<ul style="list-style-type: none"> • Used for removing caulking. • For RHD model.
 <p style="text-align: center;">ST34199AE090</p>	34199AE090	PLUG WRENCH	<ul style="list-style-type: none"> • Used for removing plug. • For RHD model.
 <p style="text-align: center;">ST34199AE100</p>	34199AE100	OIL SEAL PLUG REMOVER	<ul style="list-style-type: none"> • Used for removing oil seal plug. • For RHD model.

General Description

POWER ASSISTED SYSTEM (POWER STEERING)

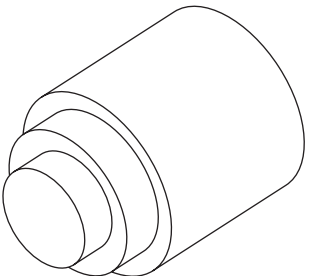
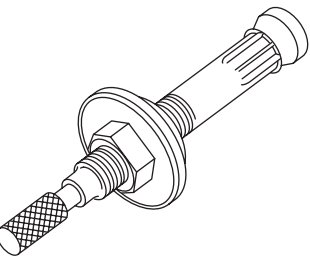
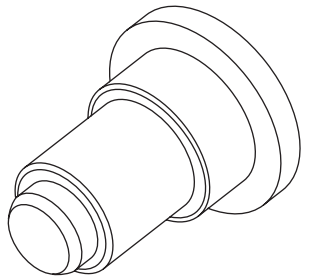
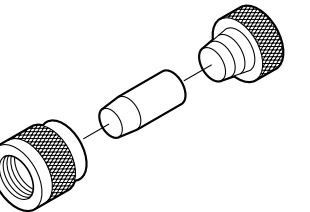
ILLUSTRATION	TOOL NUMBER	DESCRIPTION	REMARKS
 <p data-bbox="324 546 470 567">ST34199AE110</p>	34199AE110	OIL SEAL PLUG INSTALLER	<ul style="list-style-type: none"> • Used for installing oil seal plug. • For RHD model.
 <p data-bbox="324 934 470 955">ST34199AE120</p>	34199AE120	GEARBOX OIL SEAL REMOVER	<ul style="list-style-type: none"> • Used for removing gearbox oil seal. • For RHD model.
 <p data-bbox="324 1323 470 1344">ST34199AE130</p>	34199AE130	GEARBOX OIL SEAL INSTALLER	<ul style="list-style-type: none"> • Used for installing gearbox oil seal. • For RHD model.
 <p data-bbox="324 1711 470 1732">ST34199FE040</p>	34199FE040	INSTALLER A, B, C	<ul style="list-style-type: none"> • Used for installing oil seal to rack assembly. • For turbo and 3.0 R model.

General Description

POWER ASSISTED SYSTEM (POWER STEERING)

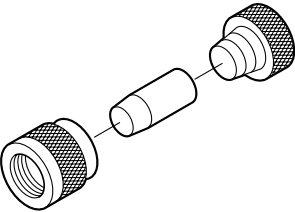
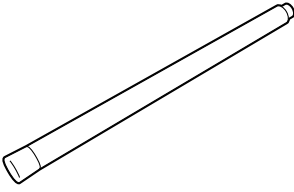
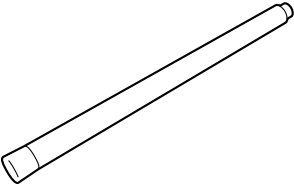
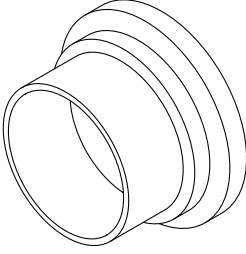
ILLUSTRATION	TOOL NUMBER	DESCRIPTION	REMARKS
 <p style="text-align: center;">ST-927490000</p>	<p style="text-align: center;">927490000</p>	<p>INSTALLER A, B, C</p>	<ul style="list-style-type: none"> • Used for installing oil seal to rack assembly. • Except for turbo and 3.0 R model.
 <p style="text-align: center;">ST34199FE010</p>	<p style="text-align: center;">34199FE010</p>	<p>REMOVER</p>	<ul style="list-style-type: none"> • Used for removing backup ring and oil seal. • For turbo and 3.0 R model.
 <p style="text-align: center;">ST-927580000</p>	<p style="text-align: center;">927580000</p>	<p>REMOVER</p>	<ul style="list-style-type: none"> • Used for removing backup ring and oil seal. • Except for turbo and 3.0 R model.
 <p style="text-align: center;">ST34199FE050</p>	<p style="text-align: center;">34199FE050</p>	<p>GUIDE</p>	<ul style="list-style-type: none"> • Used for installing rack and seal into housing assembly. • For turbo and 3.0 R model.

General Description

POWER ASSISTED SYSTEM (POWER STEERING)

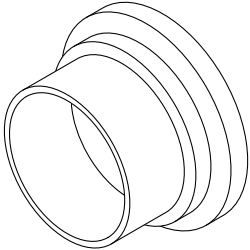
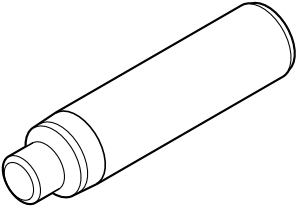
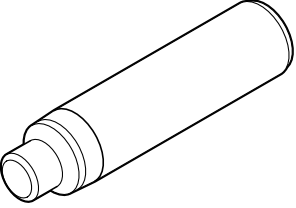
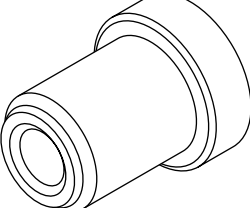
ILLUSTRATION	TOOL NUMBER	DESCRIPTION	REMARKS
 <p data-bbox="326 548 467 569">ST34199AE000</p>	34199AE000	GUIDE	<ul style="list-style-type: none"> • Used for installing rack and seal into housing assembly. • Except for turbo and 3.0 R model.
 <p data-bbox="326 936 467 957">ST34199FE000</p>	34199FE000	INSTALLER & REMOVER	<ul style="list-style-type: none"> • Used for removing and installing rack oil seal (outer & inner). • For turbo and 3.0 R model.
 <p data-bbox="326 1325 467 1346">ST34199FA030</p>	34199FA030	INSTALLER & REMOVER	<ul style="list-style-type: none"> • Used for removing and installing rack oil seal (outer & inner). • Except for turbo and 3.0 R model.
 <p data-bbox="326 1713 467 1734">ST34199FE060</p>	34199FE060	INSTALLER	<ul style="list-style-type: none"> • Used for installing rack oil seal (outer). • For turbo and 3.0 R model. • For RHD model.

General Description

POWER ASSISTED SYSTEM (POWER STEERING)

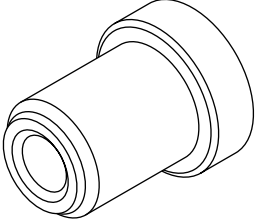
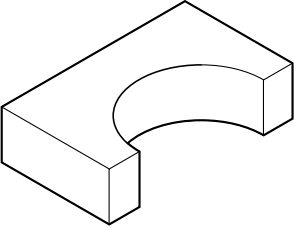
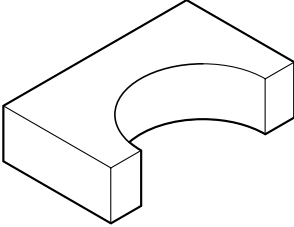
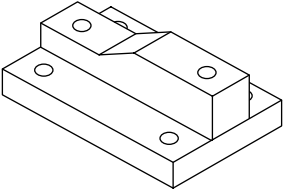
ILLUSTRATION	TOOL NUMBER	DESCRIPTION	REMARKS
 <p style="text-align: center;">ST34199AE010</p>	<p style="text-align: center;">34199AE010</p>	<p style="text-align: center;">INSTALLER</p>	<ul style="list-style-type: none"> • Used for installing rack oil seal (outer). • Except for turbo and 3.0 R model. • For RHD model.
 <p style="text-align: center;">ST34199FE020</p>	<p style="text-align: center;">34199FE020</p>	<p style="text-align: center;">BASE</p>	<ul style="list-style-type: none"> • Used for support housing assembly. • For turbo and 3.0 R model. • For RHD model.
 <p style="text-align: center;">ST34099FA070</p>	<p style="text-align: center;">34099FA070</p>	<p style="text-align: center;">BASE</p>	<ul style="list-style-type: none"> • Used for support housing assembly. • Except for turbo and 3.0 R model. • For RHD model.
 <p style="text-align: center;">ST34199AG000</p>	<p style="text-align: center;">34199AG000</p>	<p style="text-align: center;">BOSS D</p>	<ul style="list-style-type: none"> • Used for inspecting characteristic of gearbox assembly and disassembling it. • Used with STAND (926200000).

General Description

POWER ASSISTED SYSTEM (POWER STEERING)

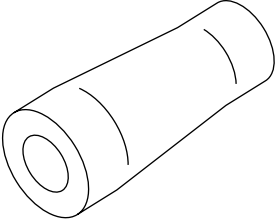
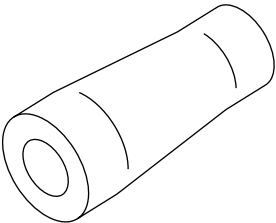
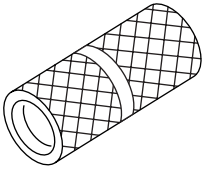
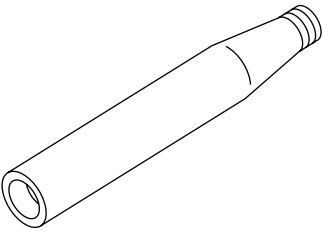
ILLUSTRATION	TOOL NUMBER	DESCRIPTION	REMARKS
 <p style="text-align: center;">ST34199AG040</p>	34199AG040	GUIDE	<ul style="list-style-type: none"> • Used for installing sealing of rack. • For 3.0 R model. • For LHD model.
 <p style="text-align: center;">ST34199AG030</p>	34199AG030	GUIDE	<ul style="list-style-type: none"> • Used for installing seal ring of rack. • Except for 3.0 R model. • For LHD model.
 <p style="text-align: center;">ST34199AG070</p>	34199AG070	FORMER	<ul style="list-style-type: none"> • Used for forming seal ring of pinion. • For LHD model.
 <p style="text-align: center;">ST34199AG020</p>	34199AG020	GUIDE	<ul style="list-style-type: none"> • Used for installing seal ring of pinion. • For LHD model.

General Description

POWER ASSISTED SYSTEM (POWER STEERING)

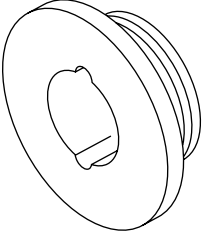
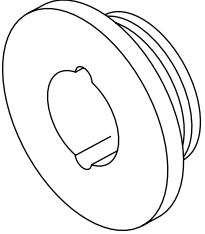
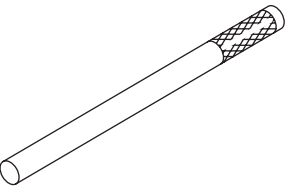
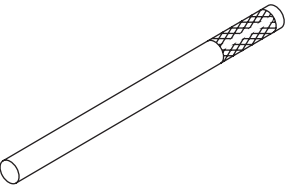
ILLUSTRATION	TOOL NUMBER	DESCRIPTION	REMARKS
 <p style="text-align: center;">ST34199AG060</p>	34199AG060	GUIDE G (26)	<ul style="list-style-type: none"> • Used for forming seal ring of rack. • For 3.0 R model. • For LHD model. • Used with FORMER PISTON (34199AG080).
 <p style="text-align: center;">ST34199AG050</p>	34199AG050	GUIDE G (24)	<ul style="list-style-type: none"> • Used for forming seal ring of rack. • Except for 3.0 R model. • For LHD model. • Used with FORMER PISTON (34199AG080).
 <p style="text-align: center;">ST34199AE050</p>	34199AE050	OIL SEAL REMOVER	<ul style="list-style-type: none"> • Used for removing oil seal. • Except for 3.0 R model. • For LHD model.
 <p style="text-align: center;">ST34099PA010</p>	34099PA010	OIL SEAL REMOVER	<ul style="list-style-type: none"> • Used for removing oil seal. • For 3.0 R model. • For LHD model.

General Description

POWER ASSISTED SYSTEM (POWER STEERING)

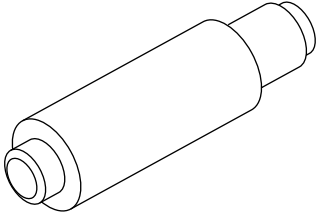
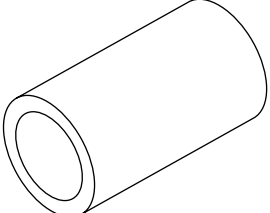
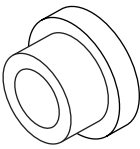
ILLUSTRATION	TOOL NUMBER	DESCRIPTION	REMARKS
 <p style="text-align: center;">ST34199AG090</p>	<p style="text-align: center;">34199AG090</p>	<p>INSTALLER & REMOVER</p>	<ul style="list-style-type: none"> • Used for installing oil seal of valve housing. • Used with SEAL INSTALLER (34099FA130). • Used for installing ball bearing of valve housing. • Used for removing oil seal and ball bearing from valve housing. • For LHD model.
 <p style="text-align: center;">ST34199AG080</p>	<p style="text-align: center;">34199AG080</p>	<p>FORMER PISTON</p>	<ul style="list-style-type: none"> • Used for forming seal of rack. • For LHD model. • Used with GUIDE G (26) (34199AG060) or GUIDE G (24) (34199AG050).
 <p style="text-align: center;">ST34199AG010</p>	<p style="text-align: center;">34199AG010</p>	<p>INSTALLER</p>	<ul style="list-style-type: none"> • Used for press-fit oil seal of gearbox cylinder. • For LHD model.

Steering Wheel

POWER ASSISTED SYSTEM (POWER STEERING)

2. Steering Wheel

A: REMOVAL

- 1) Disconnect the ground cable from battery.
- 2) Set the tire to the straight-ahead position.
- 3) Remove the airbag module. <Ref. to AB-14, REMOVAL, Driver's Airbag Module.>

WARNING:

Always refer to "Airbag System" before performing airbag module service. <Ref. to AB-4, CAUTION, General Description.>

- 4) Place alignment marks on the steering wheel and steering shaft.

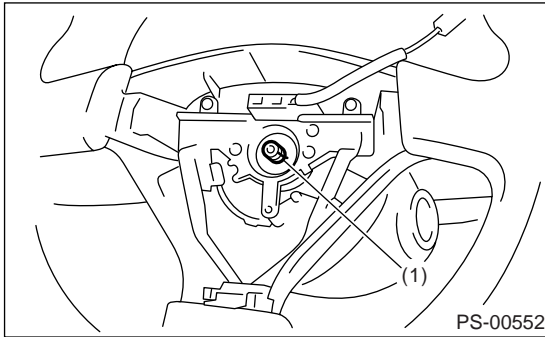

(1) Alignment mark

- 5) Remove the steering wheel nut, and then draw out the steering wheel from shaft using steering puller.

B: INSTALLATION

WARNING:

Always refer to "Airbag System" before performing airbag module service. <Ref. to AB-4, CAUTION, General Description.>

- 1) Align the center of roll connector. <Ref. to AB-23, ADJUSTMENT, Roll Connector.>
- 2) Install in the reverse order of removal.

NOTE:

Align the alignment marks on the steering wheel and steering shaft.

Tightening torque:

45 N·m (4.6 kgf·m, 33.2 ft·lb)

Column cover-to-steering wheel clearance:

2 — 4 mm (0.08 — 0.16 in)

CAUTION:

Insert roll connector guide pin into guide hole on lower end of surface of steering wheel to prevent damage.

C: INSPECTION

- 1) Check the steering wheel for deformation. If the deformation is excessive, replace the steering wheel.

- 2) Check the splines on the steering wheel for damage. If the damage is excessive, replace the steering wheel.

Universal Joint

POWER ASSISTED SYSTEM (POWER STEERING)

3. Universal Joint

A: REMOVAL

- 1) Remove the steering wheel. <Ref. to PS-20, REMOVAL, Steering Wheel.>
- 2) Place alignment marks on universal joint.
- 3) Remove the universal joint bolts and then remove the universal joint.

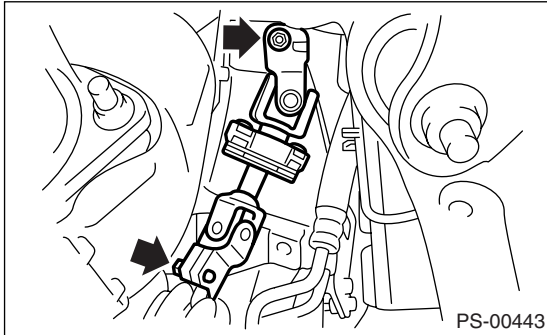

B: INSTALLATION

- 1) Align the cutout at serrated section of the column shaft and yoke, then install the universal joint into column shaft.

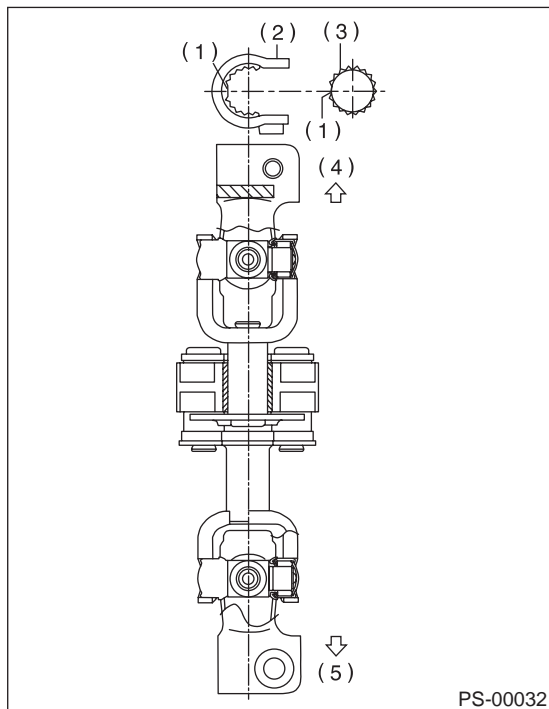

- (1) Cutout
- (2) Yoke
- (3) Column shaft
- (4) Column shaft side
- (5) Gearbox side

- 2) Install the universal joint to the serrations of gearbox assembly by matching alignment marks.
- 3) Tighten the bolt.

Tightening torque:

24 N·m (2.4 kgf·m, 17.4 ft·lb)

CAUTION:

Excessively large tightening torque of universal joint bolts may lead to heavy steering wheel operation.

Clearance between coupling of universal joint to turbo cover:

15 mm (0.59 in) or more

- 4) Align the center of roll connector. <Ref. to AB-23, ADJUSTMENT, Roll Connector.>
- 5) Install the steering wheel. <Ref. to PS-20, INSTALLATION, Steering Wheel.>

C: INSPECTION

Check for wear, damage or any other faults. If necessary, replace it.

Service limit:

Universal joint play: 0 mm (0 in)

Maximum swing torque: 0.3 N (0.03 kgf, 0.07 lb)

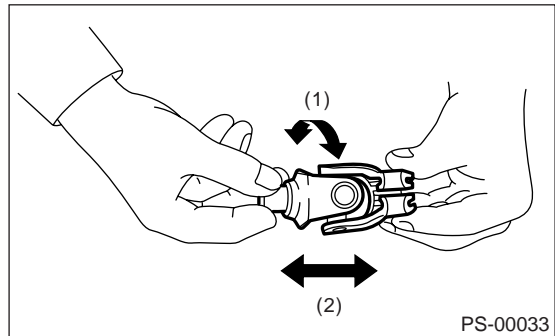

- (1) Swinging torque
- (2) Play

Measure the folding torque of universal joint.

Service limit:

Maximum load: 3.8 N (0.39 kgf, 0.86 lb) or less

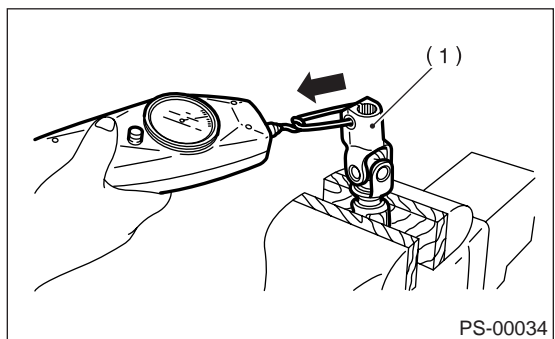

- (1) Yoke (Gearbox side)

Universal Joint

POWER ASSISTED SYSTEM (POWER STEERING)

Service limit:

Maximum load: 3.8 N (0.39 kgf, 0.86 lb) or less

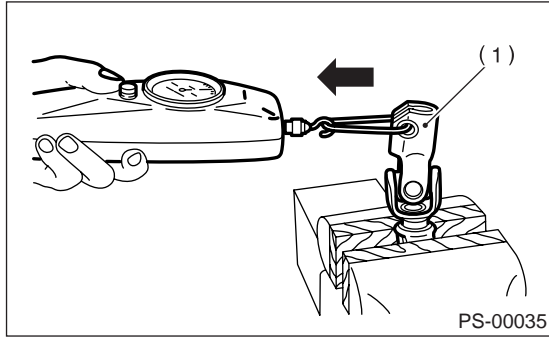

(1) Yoke (Gearbox side)

Service limit:

Maximum load: 7.3 N (0.74 kgf, 1.64 lb) or less

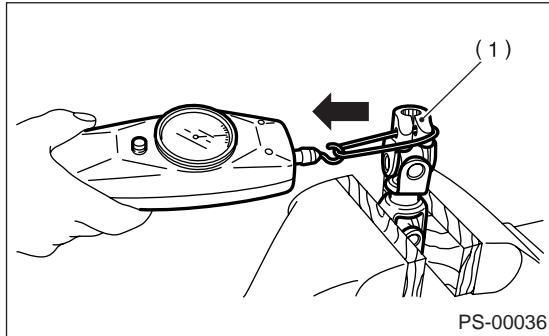

(1) Yoke (Steering column side)

Service limit:

Maximum load: 7.3 N (0.74 kgf, 1.64 lb) or less

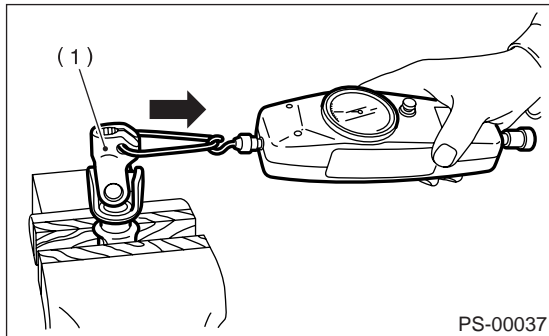

(1) Yoke (Steering column side)

Tilt Steering Column

POWER ASSISTED SYSTEM (POWER STEERING)

4. Tilt Steering Column

A: REMOVAL

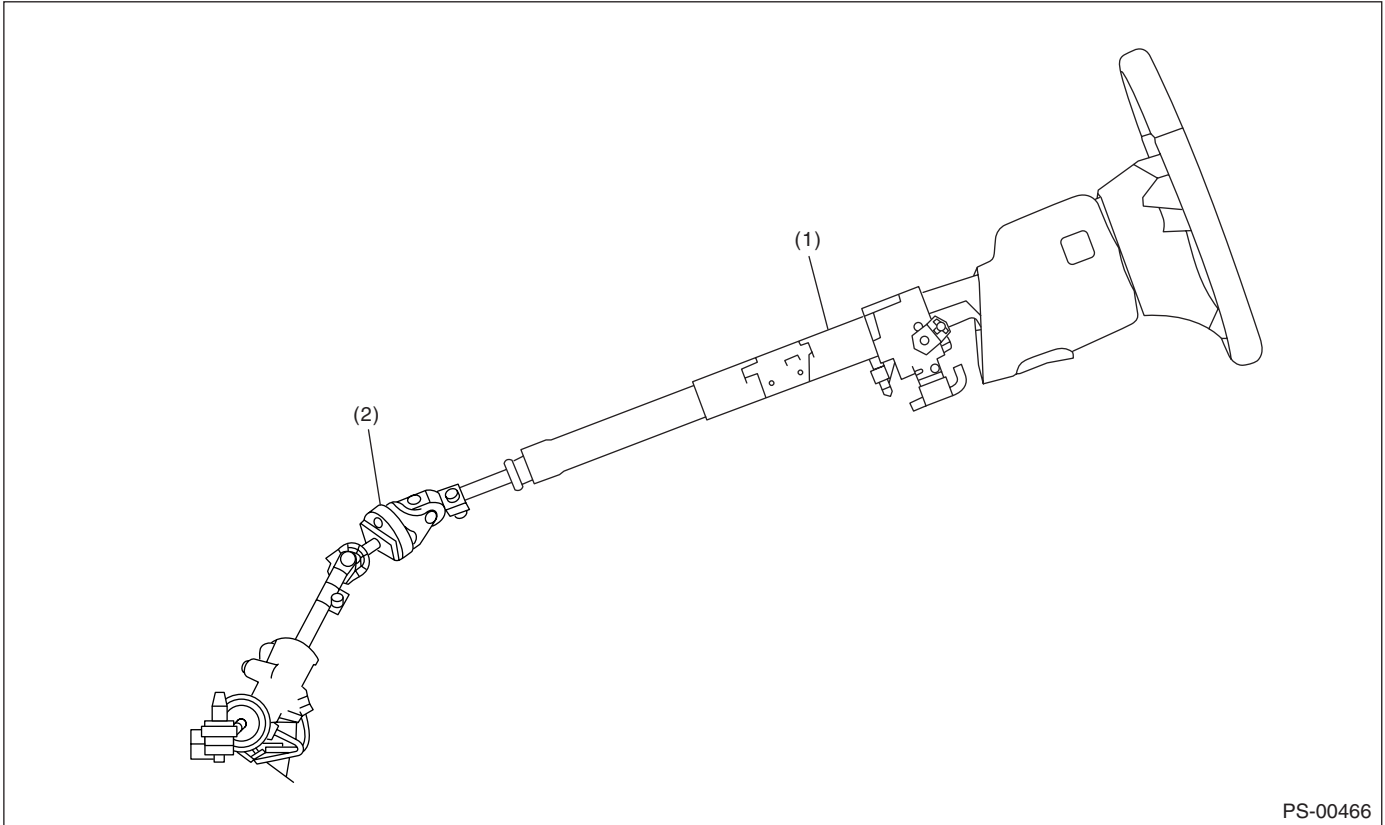

PS-00466

(1) Tilt steering column

(2) Universal joint

- 1) Remove the steering wheel. <Ref. to PS-20, REMOVAL, Steering Wheel.>
- 2) Remove the universal joint. <Ref. to PS-21, REMOVAL, Universal Joint.>
- 3) Remove the instrument panel lower cover under.
- 4) Remove the instrument panel lower cover upper.
- 5) Remove all connectors from the steering column.
- 6) Remove the two bolts under instrument panel securing steering column.

CAUTION:

- Be sure to remove the universal joint before removing steering shaft assembly installing bolts when removing steering shaft assembly or when lowering it for servicing of other parts.
- Do not loosen the tilt lever when the steering column is not secured to the vehicle.

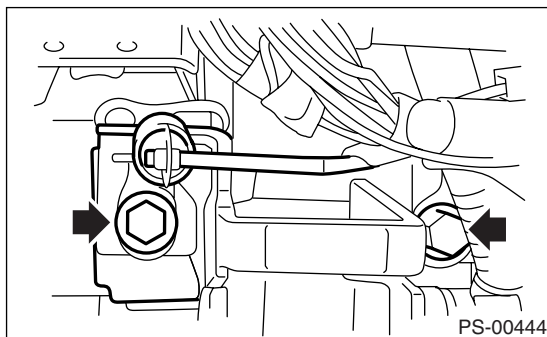

PS-00444

- 7) Pull out the steering shaft assembly from the hole on toe board.

Tilt Steering Column

POWER ASSISTED SYSTEM (POWER STEERING)

B: INSTALLATION

- 1) Install the grommet to toe board.

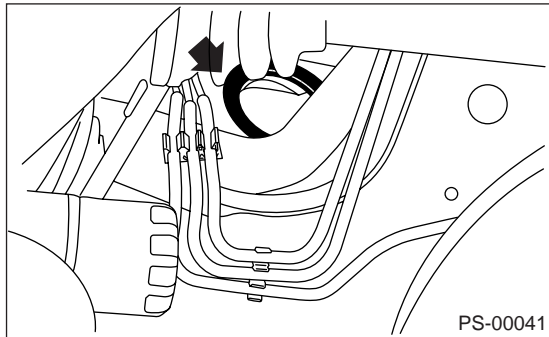

- 2) Insert the end of steering shaft into toe board grommet.
- 3) With the tilt lever secured, tighten the steering shaft mounting bolts under instrument panel.

Tightening torque:

25 N·m (2.5 kgf·m, 18.1 ft·lb)

- 4) Connect all the connectors under instrument panel.
- 5) Connect the airbag system connector at the harness spool.

NOTE:

Make sure to apply double lock.

- 6) Install the instrument panel lower cover with tilt lever held in the lowered position.
- 7) Install the universal joint. <Ref. to PS-21, INSTALLATION, Universal Joint.>
- 8) Align the center of roll connector. <Ref. to AB-23, ADJUSTMENT, Roll Connector.>
- 9) Install the steering wheel. <Ref. to PS-20, INSTALLATION, Steering Wheel.>

CAUTION:

Insert roll connector guide pin into guide hole on lower end of steering wheel surface to prevent damage.

C: DISASSEMBLY

Remove the two screws securing upper steering column covers, and the two screws securing combination switch, and then remove the related parts.

D: ASSEMBLY

Insert the combination switch to the upper column shaft, and install the upper column cover. Then route the ignition key harness and combination switch harness between column cover mounting bosses.

Tightening torque:

1.2 N·m (0.12 kgf·m, 0.9 ft·lb)

CAUTION:

Do not overtorque the screw.

E: INSPECTION

1. BASIC INSPECTION

Measure the overall length of steering column. If not as specified, replace it.

Overall length L:

Standard value

Except for OUTBACK model

833.6±1.5mm (32.82±0.059 in)

OUTBACK model

825.4±1.5mm (32.50±0.059 in)

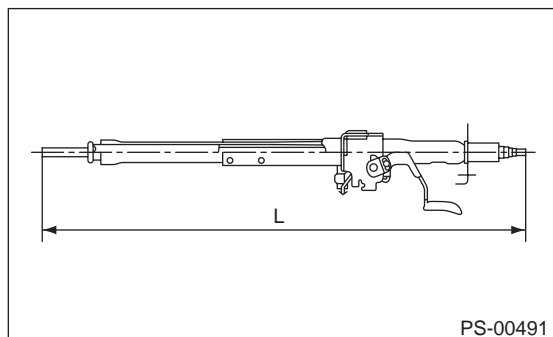

2. AIRBAG MODEL INSPECTION

WARNING:

For airbag inspection procedures, refer to “Airbag System”. <Ref. to AB-4, CAUTION, General Description.>

Steering Gearbox [LHD Model]

POWER ASSISTED SYSTEM (POWER STEERING)

5. Steering Gearbox [LHD Model]

A: REMOVAL

- 1) Set the vehicle on a lift.
- 2) Disconnect the ground cable from battery.
- 3) Loosen the front wheel nuts.
- 4) Lift-up the vehicle and remove the front wheels.
- 5) Remove the under cover. <Ref. to EI-26, REMOVAL, Front Under Cover.>
- 6) Remove the front exhaust pipe assembly. (Non-turbo model) <Ref. to EX(H4SO 2.0)-7, REMOVAL, Front Exhaust Pipe.>

WARNING:

Be careful, not to burn your hand because the exhaust pipe is hot.

- 7) Using a puller, remove the tie-rod end from the knuckle arm after pulling off cotter pin and removing castle nut.

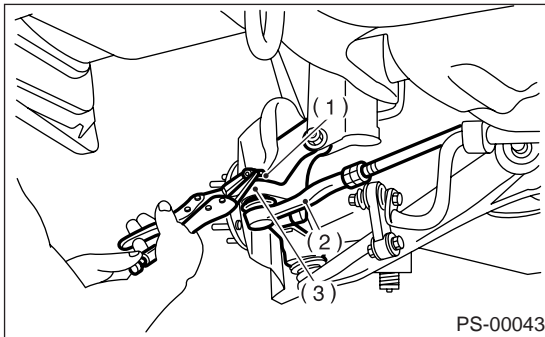

- (1) Castle nut
- (2) Tie-rod end
- (3) Knuckle arm

- 8) Remove the front crossmember support plate, jack-up plate and front stabilizer. <Ref. to FS-16, REMOVAL, Front Stabilizer.>

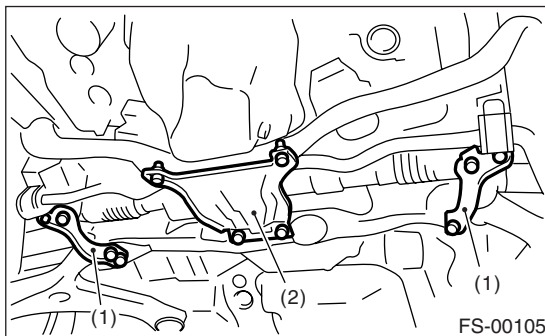

- (1) Crossmember support plate
- (2) Jack-up plate

- 9) Remove the one pipe joint at the center of gearbox, and connect the vinyl hose to the pipe and the joint. Discharge the fluid by turning steering wheel fully clockwise and counterclockwise. Discharge the fluid similarly from other pipes.

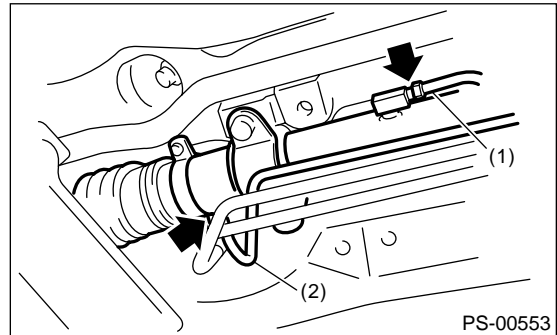

- (1) Pipe A
- (2) Pipe B

- 10) Remove the universal joint. <Ref. to PS-21, REMOVAL, Universal Joint.>
- 11) Disconnect the pipe C from pressure hose first, and pipe D from return hose second.

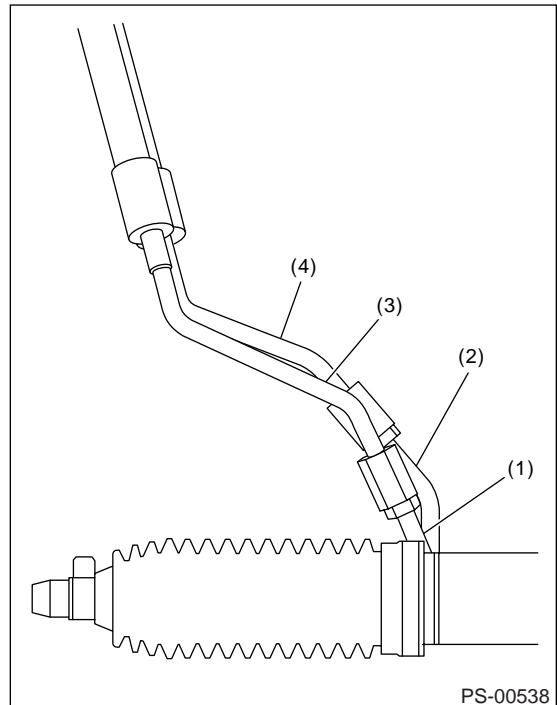

- (1) Pipe C
- (2) Pipe D
- (3) Pressure hose
- (4) Return hose

Steering Gearbox [LHD Model]

POWER ASSISTED SYSTEM (POWER STEERING)

12) Remove the clamp bolts securing gearbox to crossmember, and remove the clamp.

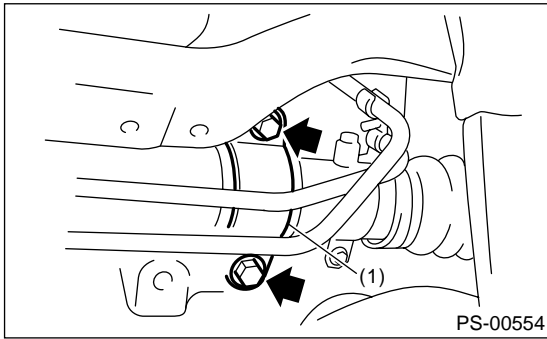

(1) Clamp

3) Tighten the gearbox to the crossmember bracket via clamp with bolt temporarily.

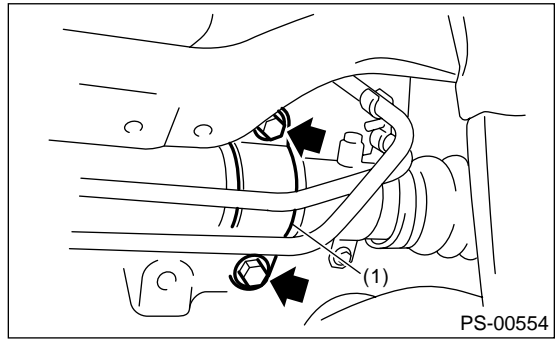

(1) Clamp

13) Remove the bolts which secure gearbox bracket, and remove the bracket and gearbox.

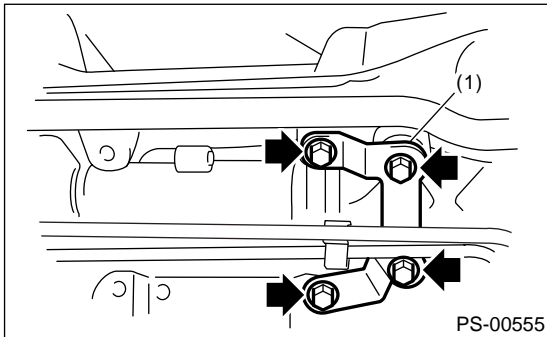

(1) Bracket

4) Tighten the bolts which temporary tightening the clamp and bracket of gearbox to specified torque.

Tightening torque:

60 N·m (6.1 kgf·m, 44.1 ft·lb)

5) Connect the pipe D to return hose first, and the pipe C to pressure hose second.

Tightening torque:

15 N·m (1.5 kgf·m, 10.8 ft·lb)

B: INSTALLATION

1) Insert the gearbox into crossmember, being careful not to damage gearbox boot.

2) Install the gearbox and bracket. Tighten the bolt temporarily.

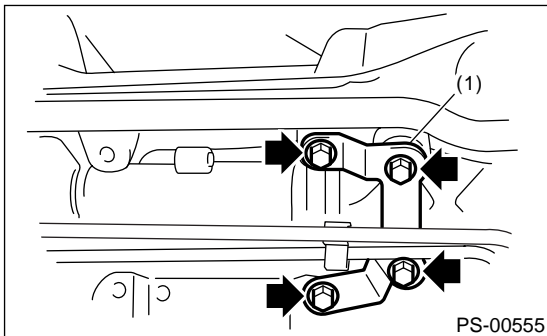

(1) Bracket

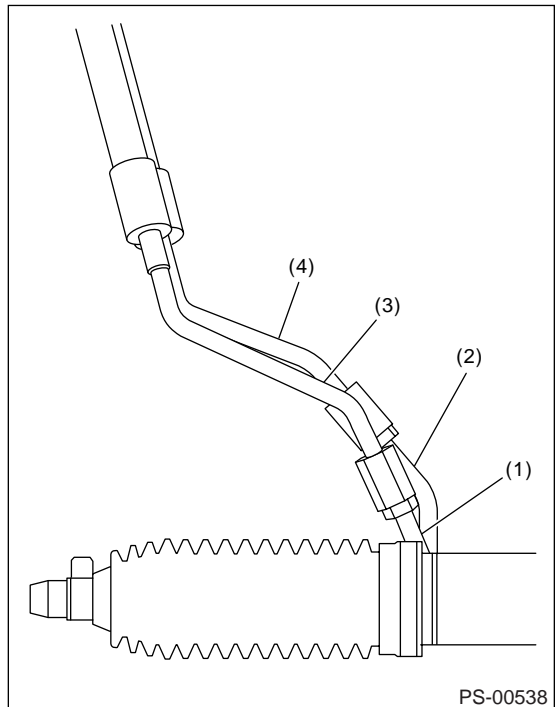

(1) Pipe C

(2) Pipe D

(3) Pressure hose

(4) Return hose

6) Install the universal joint. <Ref. to PS-21, INSTALLATION, Universal Joint.>

7) Connect the tie-rod end and knuckle arm, and tighten with castle nut.

Steering Gearbox [LHD Model]

POWER ASSISTED SYSTEM (POWER STEERING)

Castle nut tightening torque:

27 N·m (2.75 kgf·m, 19.9 ft·lb)

CAUTION:

When connecting, do not hit cap at the bottom of tie-rod end with hammer.

8) After tightening the castle nut to specified tightening torque, tighten it further within 60° until cotter pin hole is aligned with slot in the nut. Fit the cotter pin into nut, and then bend the pin to lock.

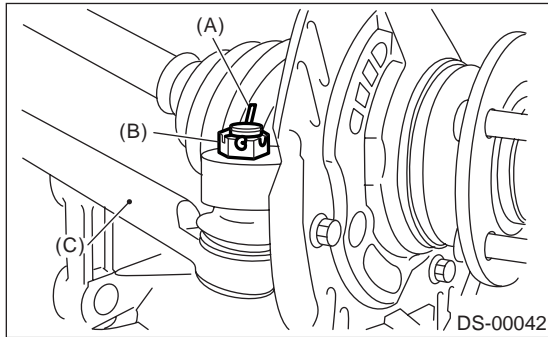

- (A) Cotter pin
- (B) Castle nut
- (C) Tie-rod end

9) Install the front stabilizer. <Ref. to FS-16, INSTALLATION, Front Stabilizer.>

10) Install the front crossmember support plate and jack-up plate.

11) Install the front exhaust pipe assembly. (Non-turbo model) <Ref. to EX(H4SO 2.0)-8, INSTALLATION, Front Exhaust Pipe.>

12) Install the under cover. <Ref. to EI-26, INSTALLATION, Front Under Cover.>

13) Install the front wheels.

14) Tighten the wheel nuts to specified torque.

Tightening torque:

90 N·m (9.1 kgf·m, 65.8 ft·lb)

15) Lower the vehicle.

16) Remove the steering wheel. <Ref. to PS-20, REMOVAL, Steering Wheel.>

17) Align the center of roll connector. <Ref. to AB-23, ADJUSTMENT, Roll Connector.>

18) Install the steering wheel. <Ref. to PS-20, INSTALLATION, Steering Wheel.>

19) Connect the battery ground cable to battery.

20) Pour fluid into the oil tank, and bleed air. <Ref. to PS-84, Power Steering Fluid.>

21) Check for fluid leaks.

22) Check the fluid level in oil tank.

23) After adjusting toe-in and steering angle, tighten the lock nut on tie-rod end.

Tightening torque:

85 N·m (8.7 kgf·m, 62.7 ft·lb)

NOTE:

When adjusting toe-in, hold the boot as shown to prevent it from being rotated or twisted. If twisted, straighten it.

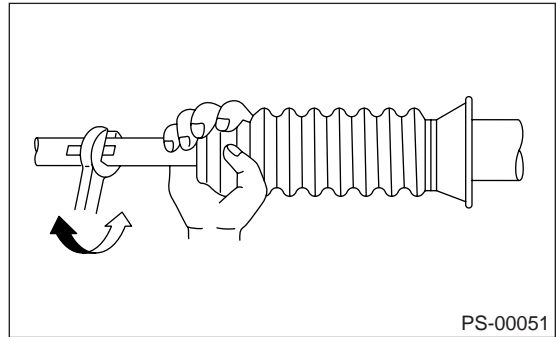

C: DISASSEMBLY

1. RACK HOUSING ASSEMBLY

1) Disconnect the four pipes from gearbox.

NOTE:

Remove the pipes C and D, which are fixed to clamp plate, as a single unit.

2) Secure the gearbox removed from vehicle in vice using ST.

ST1 926200000 STAND

ST2 34199AG000 BOSS D

CAUTION:

Secure the gearbox in a vise using ST as shown. Do not attempt to secure it without this ST.

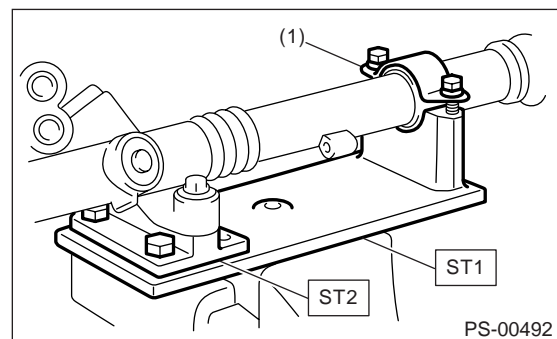

(1) Clamp

3) Remove the tie-rod end and lock nut from gearbox.

Steering Gearbox [LHD Model]

POWER ASSISTED SYSTEM (POWER STEERING)

4) Remove the small clip from the boot using pliers, and then move the boot to tie-rod end side.

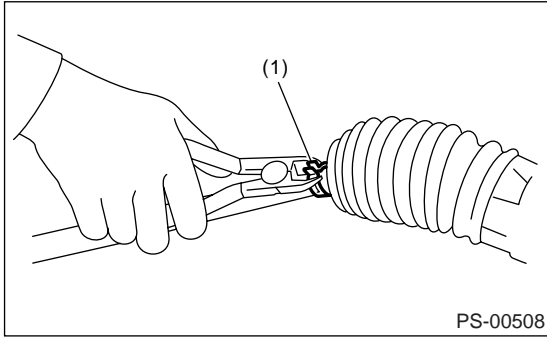

(1) Clip

5) Using a flat-tip screwdriver, remove the band from boot.

NOTE:

Replace the boot if there is damage, cracks or deterioration.

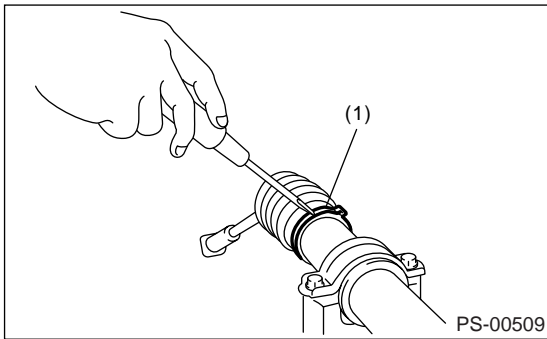

(1) Band

6) Using the ST, loosen the lock nut.
ST 926230000 SPANNER

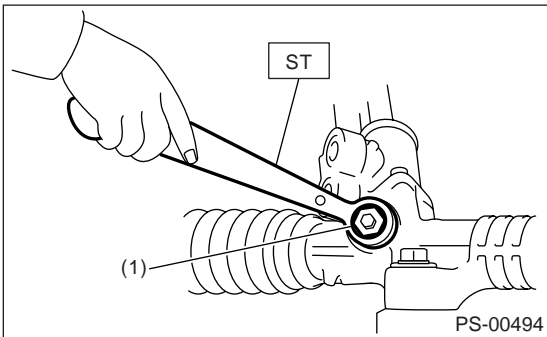

(1) Lock nut

7) Tighten the adjusting screw until it no longer tightens.

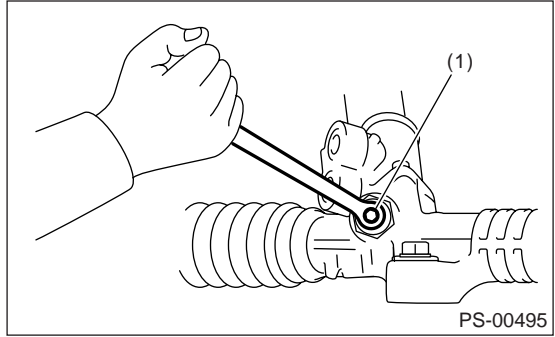

(1) Adjusting screw

8) Hold the rack with a wrench [22 mm width across flats], and then remove the tie-rod using a wrench [32 mm width across flats] or adjustable wrench.

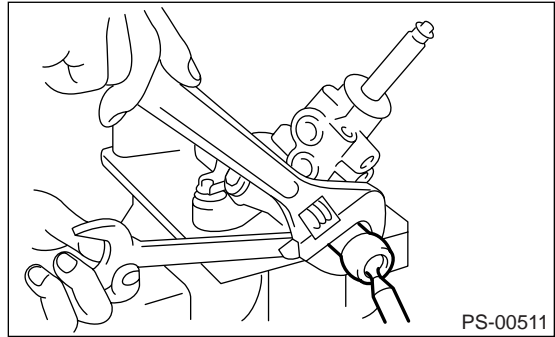

9) Loosen the adjusting screw, and then remove the spring and sleeve.

10) Remove the two bolts securing valve assembly.

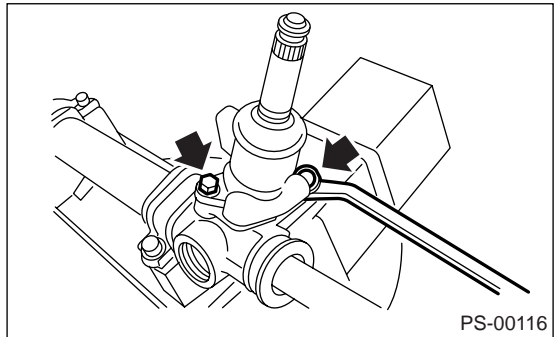

Steering Gearbox [LHD Model]

POWER ASSISTED SYSTEM (POWER STEERING)

11) Carefully draw out the input shaft, and then remove the valve assembly.

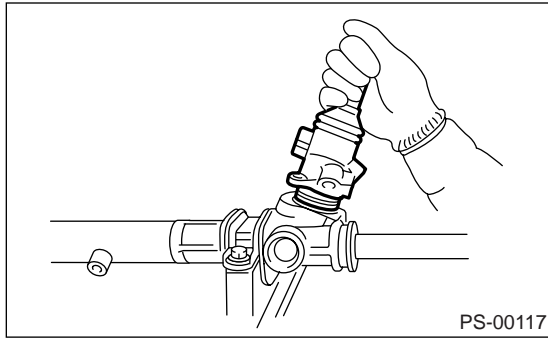

12) Using a drill, release the caulking of holder.

CAUTION:

Make a hole approx. 2 mm (0.08 in) depth using a drill bit of 3 mm (0.12 in) diameter.

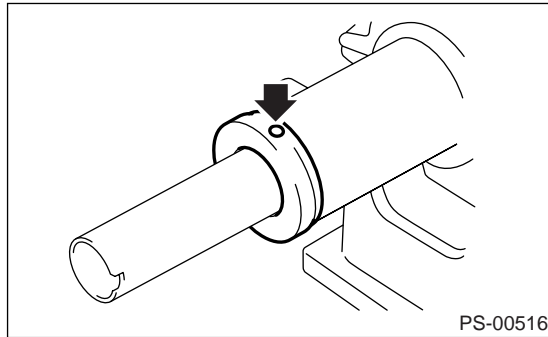

13) Using a spanner [36 mm width across flats] or adjustable wrench, remove the holder.

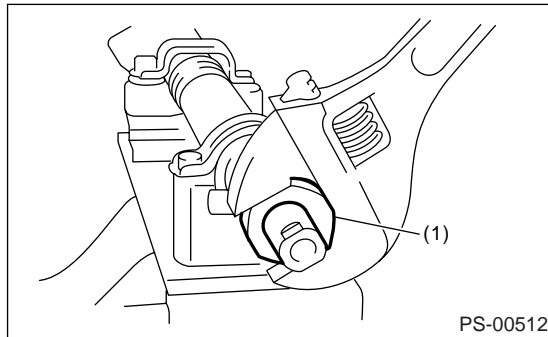

(1) Holder

14) Remove the rack bushing and rack stopper from rack assembly.

15) Remove the oil seal from rack.

16) Insert the ST from pinion housing side, and then remove the oil seal using a press.

ST 34099PA010 OIL SEAL REMOVER (3.0 R model)

ST 34199AE050 OIL SEAL REMOVER (Except for 3.0 R model)

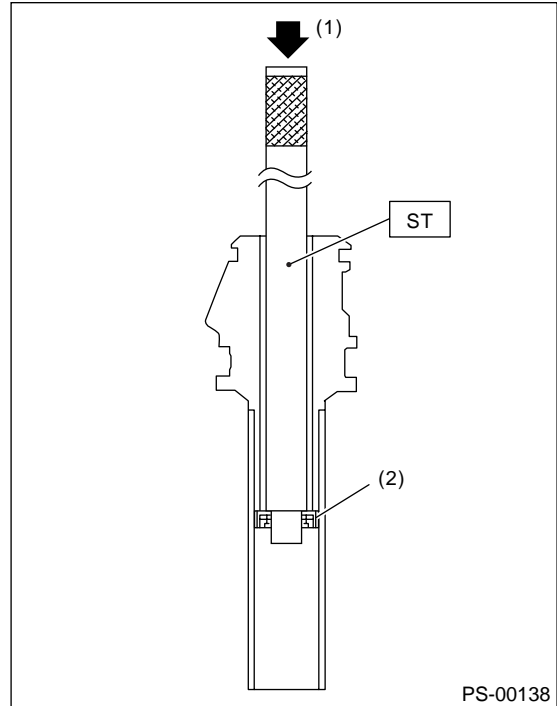

(1) Press

(2) Oil seal

17) Using a press, remove the bushing at gearbox installation portion.

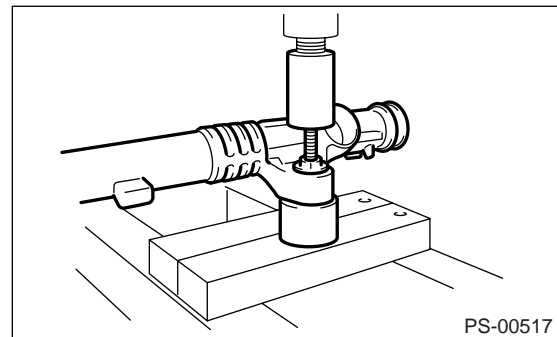

2. CONTROL VALVE

1) Disconnect the pipes A and B from gearbox.

2) Secure the gearbox removed from the vehicle in vise using ST.

ST1 926200000 STAND

ST2 34199AG000 BOSS D

Steering Gearbox [LHD Model]

POWER ASSISTED SYSTEM (POWER STEERING)

CAUTION:

Secure the gearbox in a vise using ST as shown. Do not attempt to secure it without this ST.

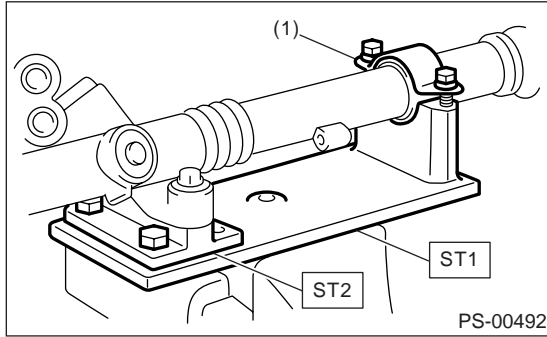

(1) Clamp

3) Using the ST, loosen the lock nut.
ST 926230000 SPANNER

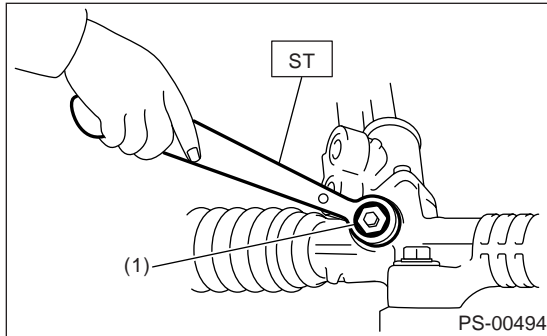

(1) Lock nut

4) Tighten the adjusting screw until it no longer tightens.

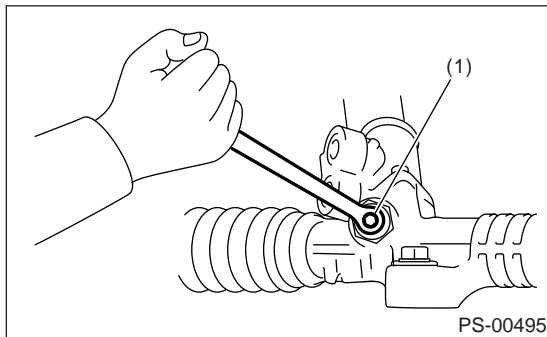

(1) Adjusting screw

5) Loosen the adjusting screw, and then remove the spring and sleeve.

6) Remove the two bolts securing valve assembly.

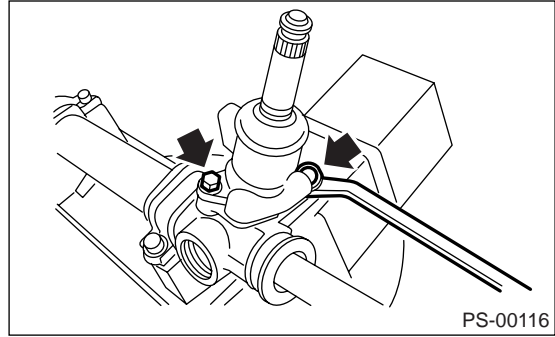

7) Carefully draw out the input shaft, and then remove the valve assembly.

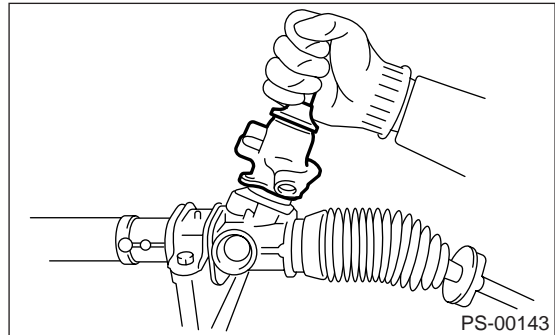

8) Wrap the tape to spline part, and slide the dust cover out.

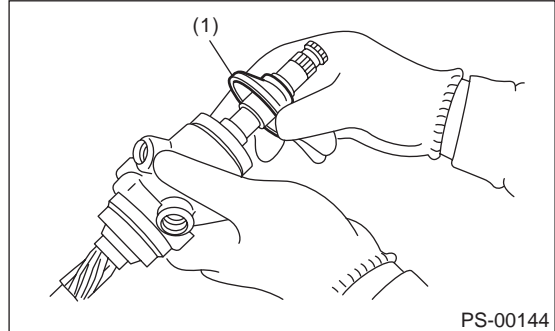

(1) Dust cover

Steering Gearbox [LHD Model]

POWER ASSISTED SYSTEM (POWER STEERING)

9) Using a press remove the pinion & valve assembly from valve housing.

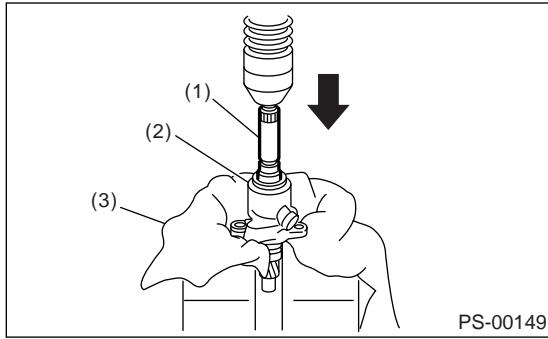

- (1) Pinion & valve ASSY
- (2) Valve housing
- (3) Cloth

10) Using the ST and press, remove the bushing and oil seal from valve housing.

ST 34199AG090 INSTALLER & REMOVER

CAUTION:

- Do not apply force to the end surface of valve housing.
- Do not reuse the oil seal after removal.

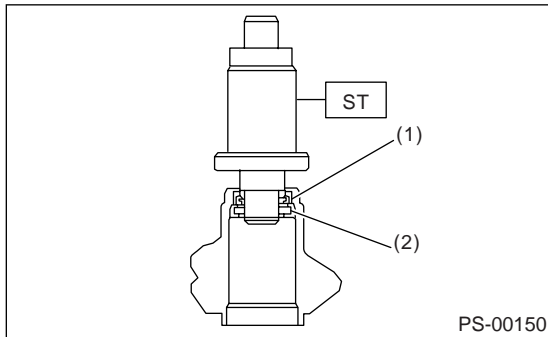

- (1) Oil seal
- (2) Bushing

11) Using a snap ring pliers, remove the snap ring, valve, oil seal and backup washer.

CAUTION:

Be careful not to scratch the pinion & valve assembly.

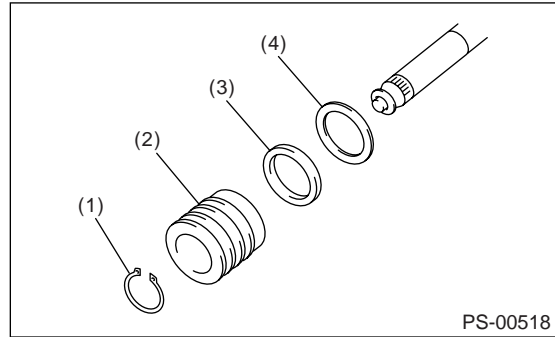

- (1) Snap ring
- (2) Valve
- (3) Oil seal
- (4) Backup ring

D: ASSEMBLY

1. RACK HOUSING ASSEMBLY

1) Using a press, install the bushing to the gearbox installation portion.

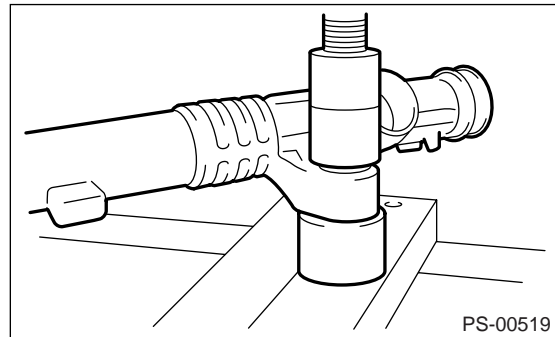

2) Insert the ST into rack.

ST 34199AG040 GUIDE (3.0 R model)

ST 34199AG030 GUIDE (Except for 3.0 R model)

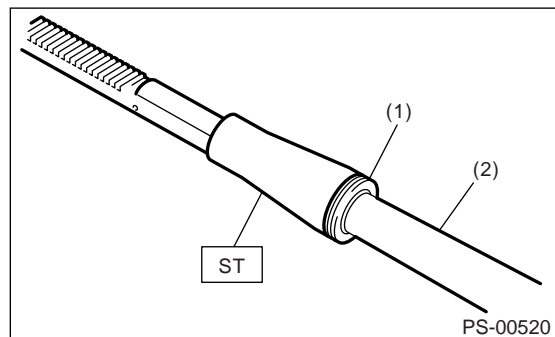

- (1) Seal ring
- (2) Rack

Steering Gearbox [LHD Model]

POWER ASSISTED SYSTEM (POWER STEERING)

3) Install the seal ring to piston portion of rack.

- (1) Using the ST, form the seal ring properly
 ST1 34199AG080 FORMER PISTON
 ST2 34199AG060 GUIDE G (26) (3.0 R model)
 ST2 34199AG050 GUIDE G (24) (Except for 3.0 R model)

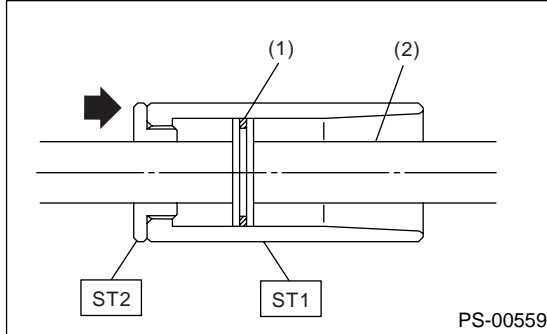

- (1) Seal ring
 (2) Rack

(2) Using ST-B and ST-C, install the oil seal to ST-A.

- ST 34199FE040 INSTALLER A, B, C (3.0 R model)
 ST 927490000 INSTALLER A, B, C (Except for 3.0 R model)

NOTE:

Face the oil seal in the direction as shown in the figure.

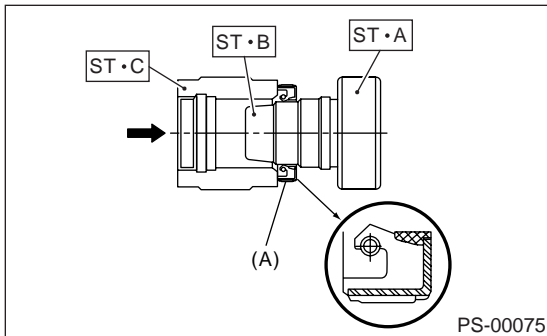

- (A) Oil seal

(3) Insert the ST-A with oil seal assembled from the gear side of rack. Remove the oil seal from ST-A near piston, and then remove the ST-A from rack.

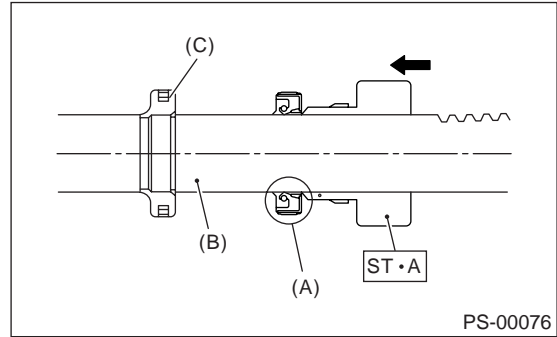

- (A) Oil seal
 (B) Rack
 (C) Piston

4) Install the backup washer from gear side of rack.

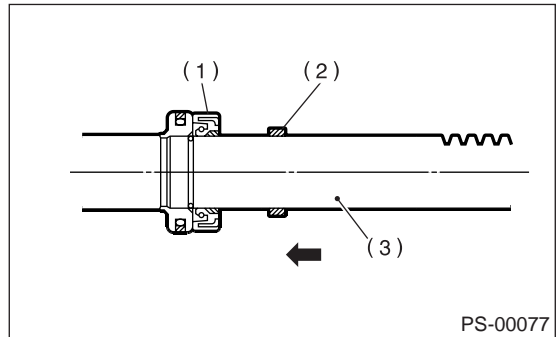

- (1) Oil seal
 (2) Backup washer
 (3) Rack

5) Install the ST on rack, and equally apply a thin coat of grease to the rack and ST, then install the oil seal.

- ST 926250000 GUIDE

CAUTION:

Be careful not to scratch the oil seal lips with the inner ring section of piston.

Steering Gearbox [LHD Model]

POWER ASSISTED SYSTEM (POWER STEERING)

NOTE:

Do not use this ST for turbo model.

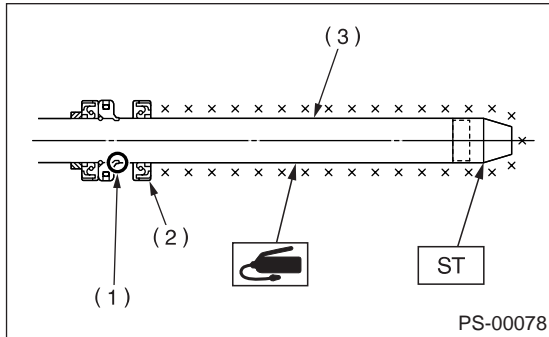

- (1) Rack piston inner ring
- (2) Outer side oil seal
- (3) Rack

6) Apply a coat of grease to the grooves in rack, sliding surface of sleeve and sealing surface of piston. Then insert the rack into steering body from cylinder side.

7) Check the thread part of holder and end of gearbox cylinder for burrs and scratches. Correct if necessary.

8) Insert the ST into gearbox cylinder, and then press-fit the oil seal.

ST 34199AG010 INSTALLER

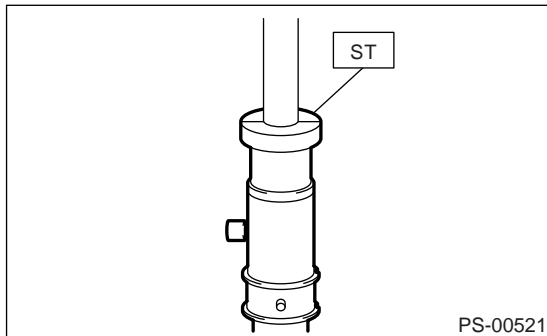

9) Temporarily install the holder to gearbox cylinder.

10) Set the ST to the end of rack.

ST 34199FE000 INSTALLER & REMOVER
(3.0 R model)

ST 34099FA030 INSTALLER & REMOVER
(Except for 3.0 R model)

11) Using a press, press-fit until the groove of ST reaches the end of holder.

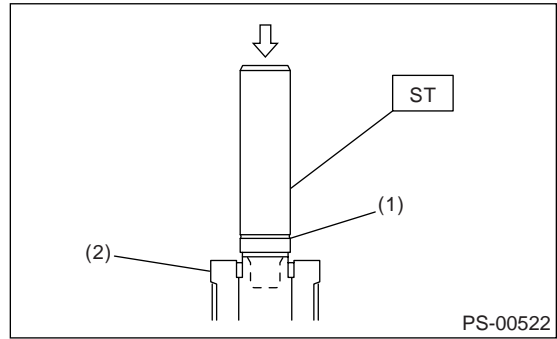

- (1) Groove
- (2) Holder

12) Secure the gearbox in a vice using ST.

ST1 926200000 STAND

ST2 34199AG000 BOSS D

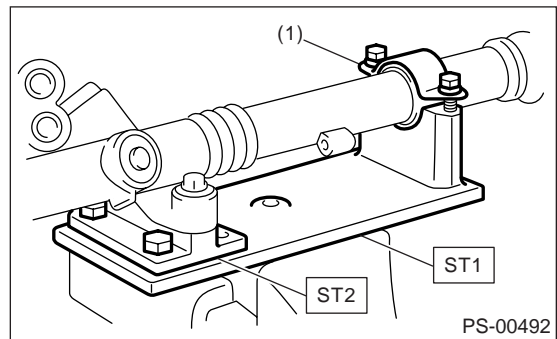

- (1) Clamp

13) Tighten the holder.

Tightening torque:

3.0 R model

90 N·m (9.18 kgf·m, 66.4 ft·lb)

Except for 3.0 R model

64 N·m (6.5 kgf·m, 47.0 ft·lb)

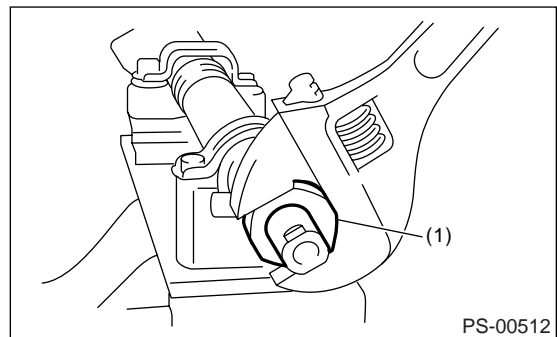

- (1) Holder

14) Using ST, caulk the gearbox cylinder at 2 mm (0.08 in) from end to make punch hole 2 to 2.5 mm (0.08 to 0.10 in) in diameter.

Steering Gearbox [LHD Model]

POWER ASSISTED SYSTEM (POWER STEERING)

ST 34099FA060 PUNCH HOLDER

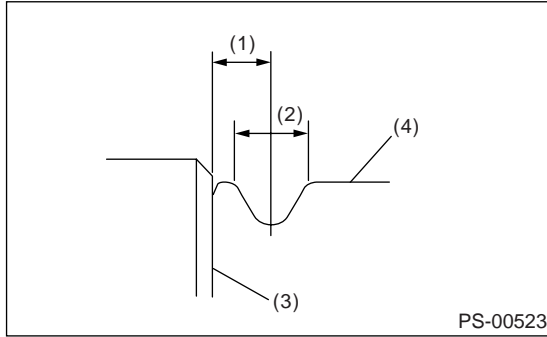

- (1) 2 mm (0.08 in)
- (2) Diameter: 2 — 2.5 mm (0.08 — 0.10 in)
- (3) End of cylinder
- (4) Holder

15) Apply vinyl tape to spline portion, and apply genuine grease to dust cover, and then install the dust cover to valve assembly.

CAUTION:

Be sure to install the dust cover to groove on shaft properly.

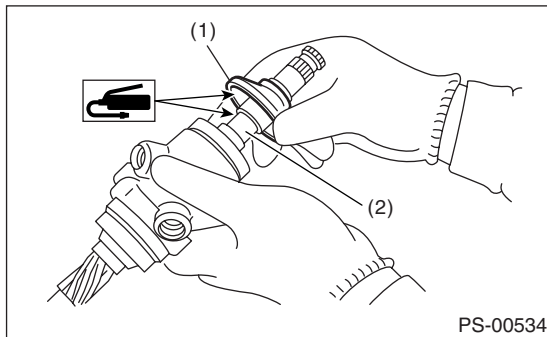

- (1) Dust cover
- (2) Groove

16) Apply genuine grease to the pinion gear and bearing of valve assembly.

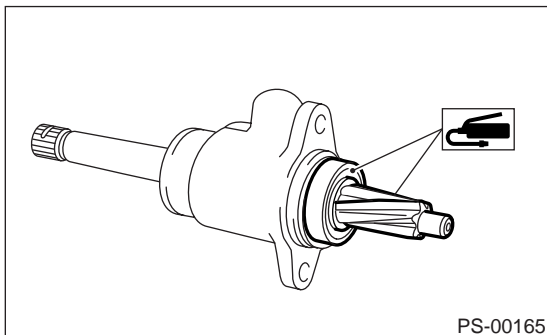

17) Install a new gasket on valve assembly. Insert the valve assembly into place while facing the rack teeth toward pinion.

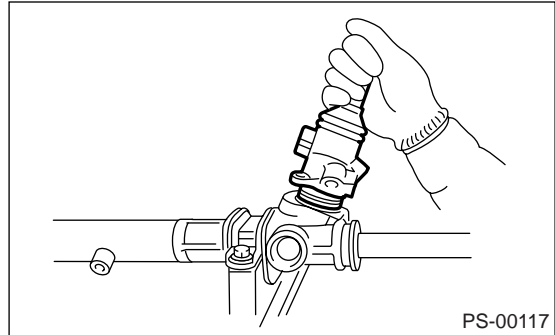

18) Tighten the bolts alternately to secure valve assembly.

Tightening torque:

25 N·m (2.5 kgf-m, 18.1 ft-lb)

CAUTION:

Be sure to alternately tighten the bolts.

19) Temporarily install the rack, and then operate it from lock to lock two or three times to make it fit in. Remove the grease blocking air vent hole.

CAUTION:

If operating the rack from lock to lock without installing tie-rod, it may damage the oil seal. Always install the tie-rods LH and RH.

20) Apply a coat of grease to the sliding surface of sleeve and seating surface of spring, and then insert sleeve into steering body.

Charge the adjusting screw with grease, and then insert the spring into adjusting screw and install on steering body.

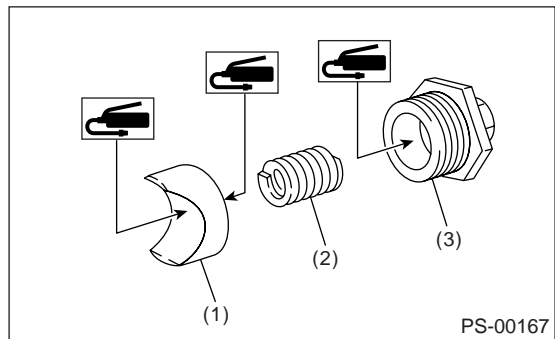

- (1) Sleeve
- (2) Spring
- (3) Adjusting screw

21) Tighten the adjusting screw to specified torque.

Tightening torque:

7.4 N·m (0.75 kgf-m, 5.4 ft-lb)

22) After tightening the adjusting screw with the specified tightening torque, loosen it by 25°.

23) Remove the tie-rod.

Steering Gearbox [LHD Model]

POWER ASSISTED SYSTEM (POWER STEERING)

24) Verify that play is within specified value. <Ref. to PS-43, SERVICE LIMIT, INSPECTION, Steering Gearbox [LHD Model].>

25) Loosen the adjusting screw, and then apply liquid gasket to at least 1/3 of the entire perimeter of adjusting screw thread.

Liquid gasket:
THREE BOND 1141

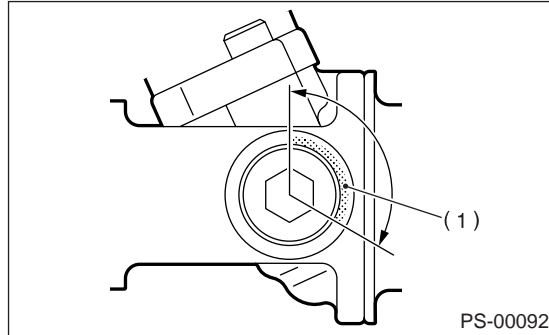

(1) Apply liquid gasket to at least 1/3 of entire perimeter.

26) Tighten the adjusting screw to specified torque.

Tightening torque:
7.4 N·m (0.75 kgf-m, 5.4 ft-lb)

27) After tightening the adjusting screw with the specified tightening torque, loosen it by 25°.

28) Install the lock nut. While holding the adjusting screw with a wrench, tighten lock nut using ST. ST 926230000 SPANNER

Tightening torque (Lock nut):
39 N·m (4.0 kgf-m, 28.9 ft-lb)

NOTE:

Hold the adjusting screw with a wrench to prevent it from turning while tightening lock nut.

29) Extend the rack approx. 40 mm (1.57 in) beyond side of steering body.

30) Install the tie-rod and a new lock washer into rack.

Tightening torque:

78 N·m (8.0 kgf-m, 57.9 ft-lb)

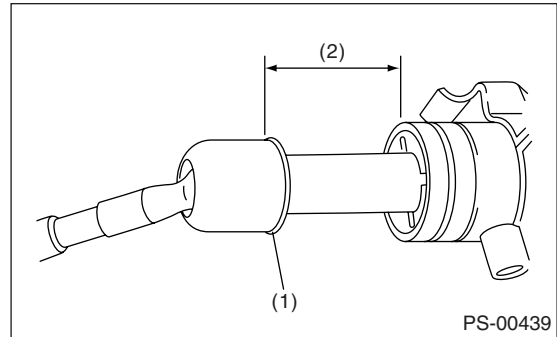

(1) Lock washer
(2) Approx. 40 mm (1.57 in)

31) Bend the lock washer.

CAUTION:
Be careful not to scratch the rack when bending lock washer.

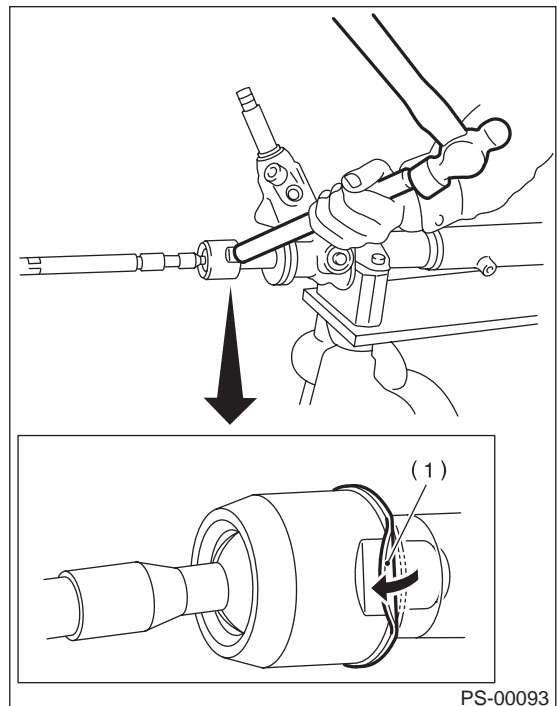

(1) Lock washer

32) Apply a coat of grease to the tie-rod groove, and then install the boot to housing.

Steering Gearbox [LHD Model]

POWER ASSISTED SYSTEM (POWER STEERING)

CAUTION:

Right side boot has groove for identification.
Be sure to install the boots after identifying left and right boots.

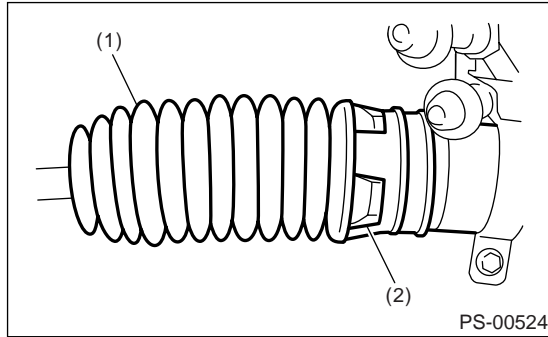

- (1) Right side boot
- (2) Groove for identification

NOTE:

Make sure that the boot is installed without unusual inflation or deflation.

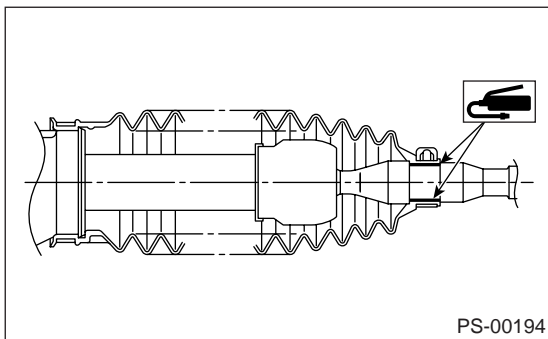

33) Install a new boot band. Using band clamp pliers, caulk the boot band until caulking part clearance is 2 mm (0.079 in) or less.

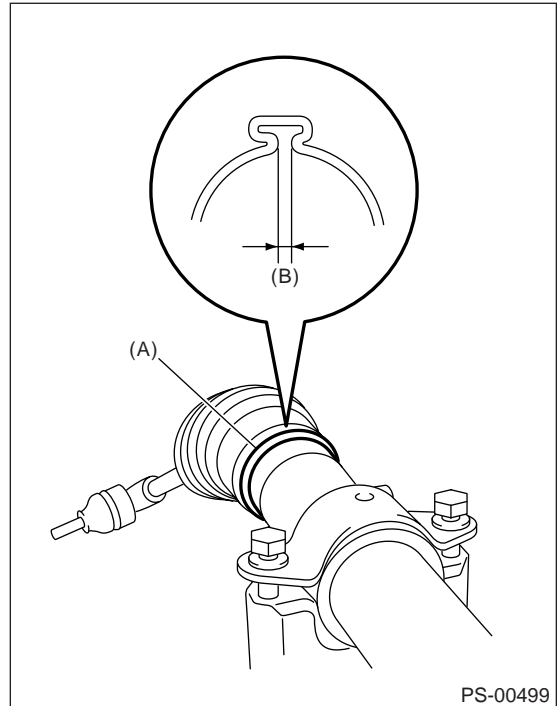

- (A) Boot band
- (B) 2 mm (0.079 in) or less

34) Fix the boot end with clip (small).

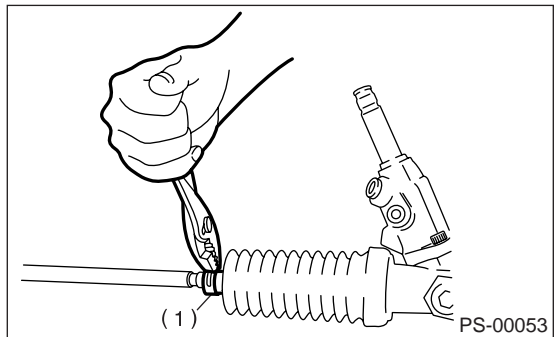

- (1) Clip

35) After installing, check the boot end is positioned into groove on tie-rod.

36) If the tie-rod end has been removed, screw in the lock nut and tie-rod end to screwed portion of tie-rod, and then tighten the lock nut temporarily in a position as shown in the figure.

Steering Gearbox [LHD Model]

POWER ASSISTED SYSTEM (POWER STEERING)

Installed tie-rod length L:
31 mm (1.22 in)

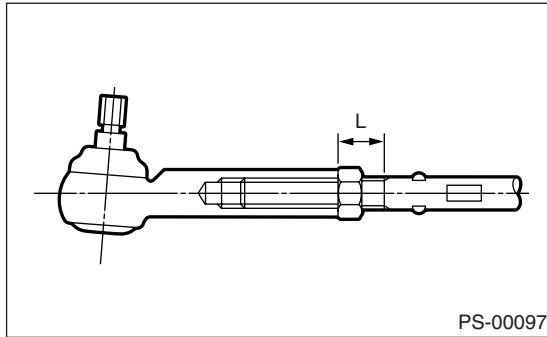

37) Inspect the gearbox as follows:
"A" Holding the tie-rod end, repeat lock to lock two or three times as quickly as possible.
"B" Holding the tie-rod end, turn it slowly at a radius one or two times as large as possible.
After all, make sure that the boot is installed in specified position without deflation.

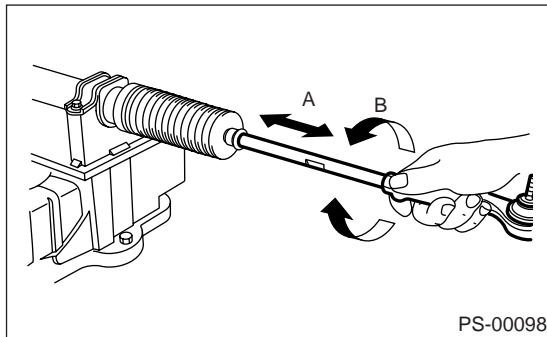

38) Remove the gearbox from ST.

ST1 926200000 STAND

ST2 34199AG000 BOSS D

39) Install the four pipes on gearbox.

(1) Connect the pipe A and B to four pipe joints of gearbox.

Tightening torque:

13 N·m (1.3 kgf·m, 9.4 ft·lb)

(2) Connect the pipe C and D to gearbox.

Tightening torque:

Pipe C: 15 N·m (1.5 kgf·m, 10.8 ft·lb)

Pipe D: 25 N·m (2.5 kgf·m, 18.1 ft·lb)

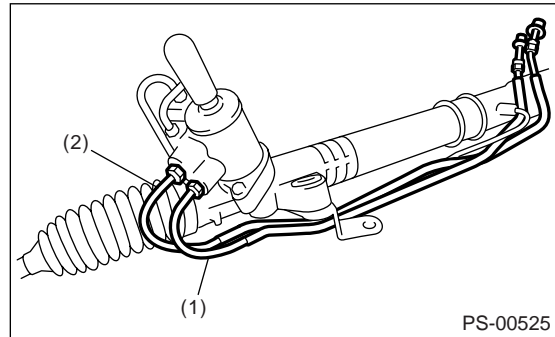

(1) Pipe C

(2) Pipe D

2. CONTROL VALVE ASSEMBLY

Specified steering grease:

VALIANT GREASE M2 (Part No. 003608001)

- 1) Clean all parts and tools before reassembling.
- 2) Apply a coat of specified power steering fluid to the inner wall of valve housing.

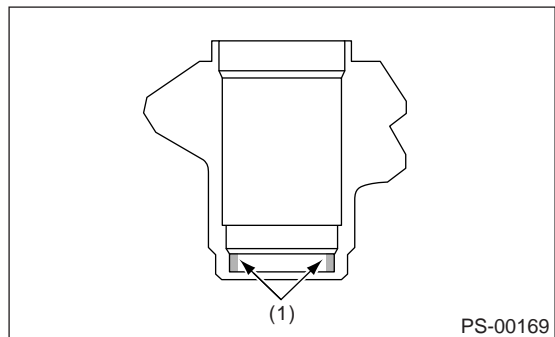

(1) Apply fluid.

3) To avoid scratching the oil seal, apply a coat of grease to the contact surface of installer and oil seal.

4) Verify the oil seal direction.

Attach the oil seal to installer and position in valve housing before pressing into place.

Steering Gearbox [LHD Model]

POWER ASSISTED SYSTEM (POWER STEERING)

5) Press the oil seal into place using a press.
ST 34199AG090 INSTALLER & REMOVER

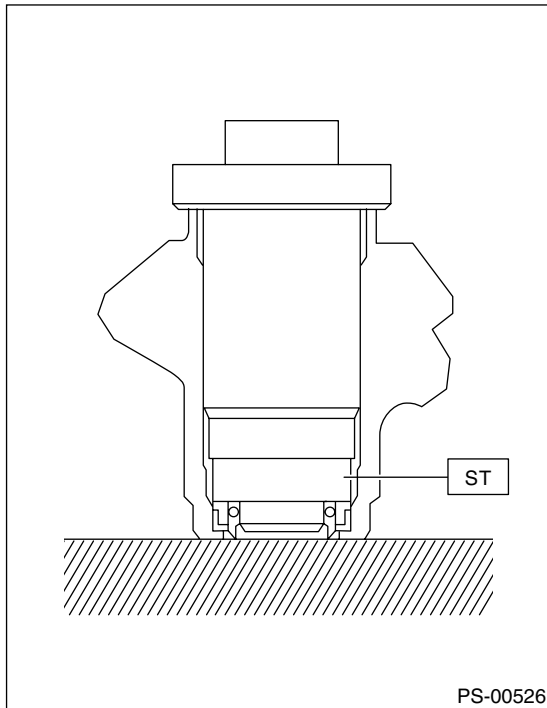

6) Attach the bearing to ST, and then position in value housing. Using the ST and press, install the special bearing in valve housing.
ST 34199AG090 INSTALLER & REMOVER

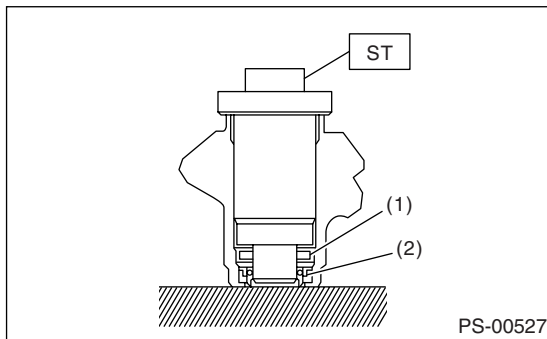

- (1) Special bearing
- (2) Oil seal

7) Apply vinyl tape to the groove portion of pinion.

8) Install the backup ring and oil seal to pinion, and then remove the vinyl tape.

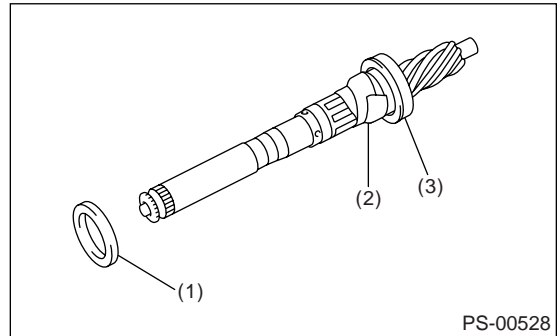

- (1) Oil seal
- (2) Vinyl tape
- (3) Backup ring

9) Set the ST to pinion, and install the seal ring.
ST 34199AG020 GUIDE

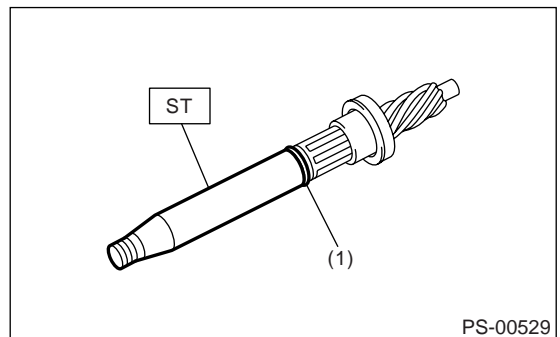

- (1) Seal ring

10) Remove the ST GUIDE, and form the seal ring properly using ST FORMER.
ST 34199AG070 FORMER

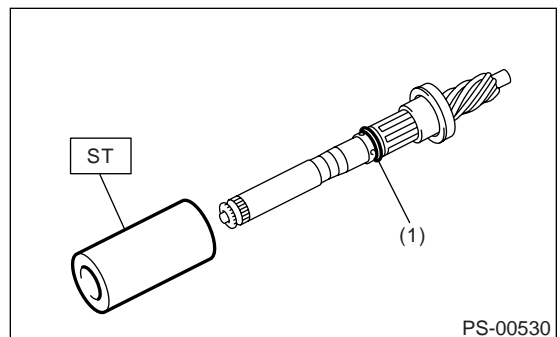

- (1) Seal ring

11) Put vinyl tape around the pinion shaft splines to protect oil seal from damage.

Steering Gearbox [LHD Model]

POWER ASSISTED SYSTEM (POWER STEERING)

12) Install the valve to pinion, and install the snap ring.

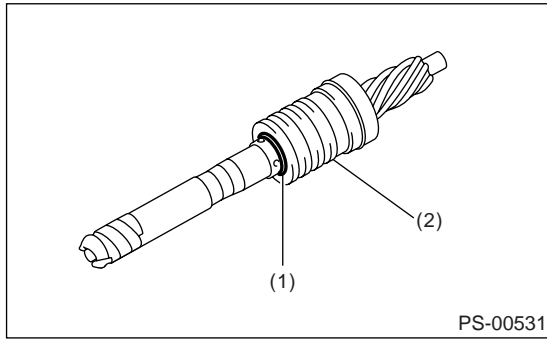

- (1) Snap ring
- (2) Valve

13) Fit the pinion & valve assembly into valve housing.

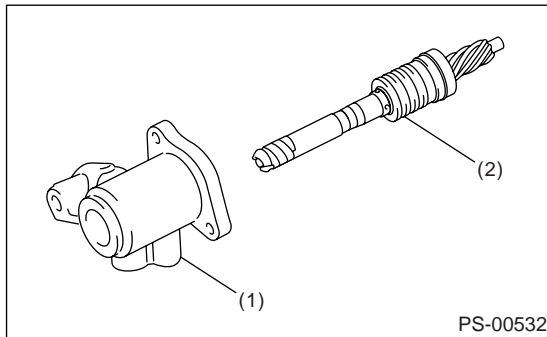

- (1) Valve housing
- (2) Pinion & valve ASSY

14) Using a press, press-fit the pinion & valve assembly into housing by pressing the bearing outer race.

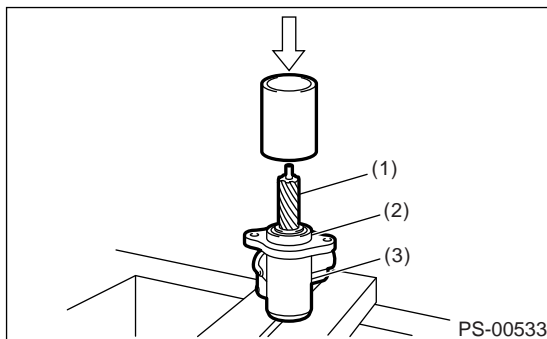

- (1) Pinion & valve ASSY
- (2) Bearing
- (3) Housing

15) Apply the specified grease to dust cover.

16) Install the dust cover on valve assembly.

CAUTION:

Be sure to install the dust cover to groove on shaft properly.

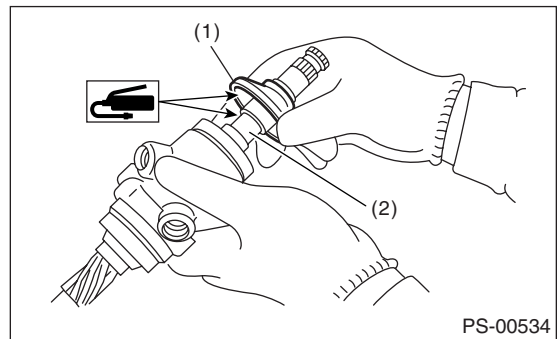

- (1) Dust cover
- (2) Groove

17) Apply genuine grease to the pinion gear and bearing of valve assembly.

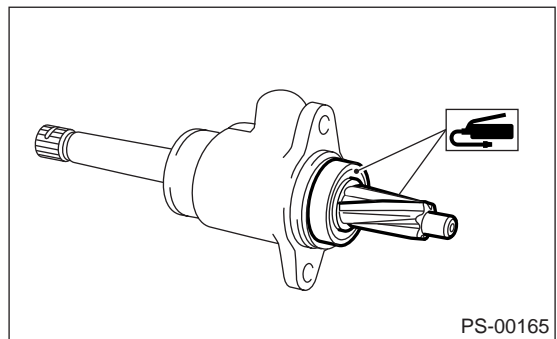

18) Install a new O-ring on valve assembly.

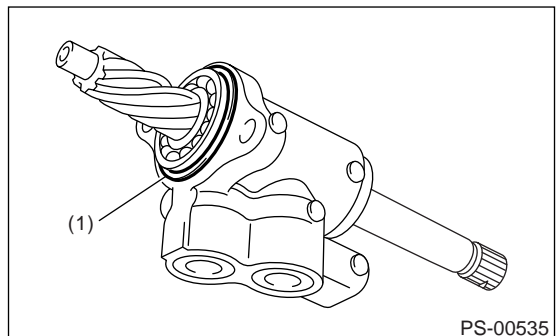

- (1) O-ring

Steering Gearbox [LHD Model]

POWER ASSISTED SYSTEM (POWER STEERING)

19) Insert the valve assembly into place while facing rack teeth toward pinion.

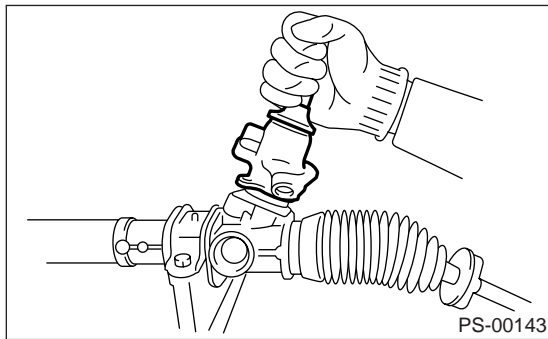

20) Tighten the bolts alternately to secure valve assembly.

Tightening torque:

25 N·m (2.5 kgf-m, 18.1 ft-lb)

CAUTION:

Be sure to alternately tighten the bolts.

21) Apply a coat of grease to the sliding surface of sleeve and seating surface of spring, and then insert the sleeve into steering body.

Charge the adjusting screw with grease, and then insert the spring into adjusting screw and install on steering body.

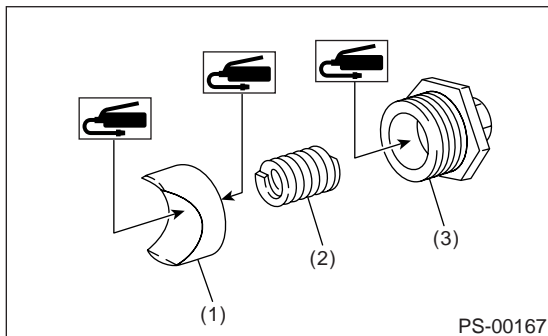

- (1) Sleeve
- (2) Spring
- (3) Adjusting screw

22) Tighten the adjusting screw with specified torque.

Tightening torque:

7.4 N·m (0.75 kgf-m, 5.4 ft-lb)

23) After tightening to the specified tightening torque, loosen it by 25°.

24) Verify that play is within specified value. <Ref. to PS-43, SERVICE LIMIT, INSPECTION, Steering Gearbox [LHD Model].>

25) Loosen the adjusting screw, and then apply liquid gasket to at least 1/3 of the entire perimeter of adjusting screw thread.

Liquid gasket:

THREE BOND 1141

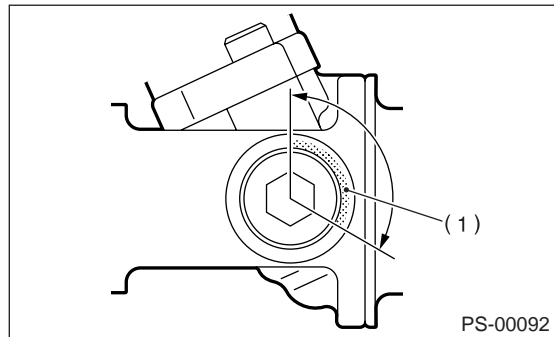

- (1) Apply liquid gasket to at least 1/3 of entire perimeter.

26) Tighten the adjusting screw to specified torque.

Tightening torque:

7.4 N·m (0.75 kgf-m, 5.4 ft-lb)

27) After tightening to the specified tightening torque, loosen it by 25°.

28) Install the lock nut. While holding the adjusting screw with a wrench, tighten the lock nut using ST. ST 926230000 SPANNER

Tightening torque (Lock nut):

39 N·m (4.0 kgf-m, 28.9 ft-lb)

NOTE:

Hold the adjusting screw with a wrench to prevent it from turning while tightening lock nut.

29) Remove the gearbox from ST.

ST1 926200000 STAND

ST2 34199AG000 BOSS D

30) Install the four pipes on gearbox.

- (1) Connect the pipe A and B to the gearbox.

Tightening torque:

13 N·m (1.3 kgf-m, 9.4 ft-lb)

Steering Gearbox [LHD Model]

POWER ASSISTED SYSTEM (POWER STEERING)

(2) Connect the pipe C and D to gearbox.

Tightening torque:

Pipe C: 15 N·m (1.5 kgf·m, 10.8 ft·lb)

Pipe D: 25 N·m (2.5 kgf·m, 18.1 ft·lb)

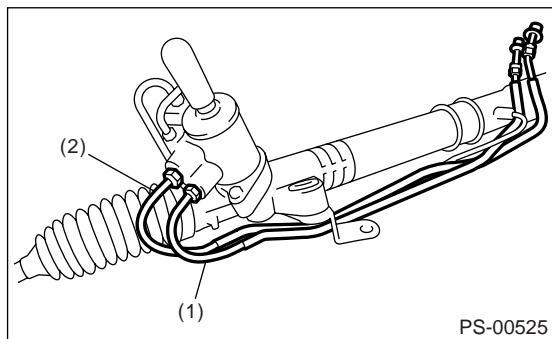

(1) Pipe C

(2) Pipe D

Steering Gearbox [LHD Model]

POWER ASSISTED SYSTEM (POWER STEERING)

E: INSPECTION

1. BASIC INSPECTION

1) Clean all disassembled parts, and check for wear, damage or any other faults, then repair or replace as necessary.

2) When disassembling, check the inside of gearbox for water. If any water is found, carefully check the boot for damage, input shaft dust seal, adjusting screw and boot clips for poor sealing. If faulty, replace with new parts.

No.	Parts	Inspection	Corrective action
1	Input shaft	(1) Bend of input shaft (2) Damage on serration	If the bend or damage is excessive, replace the entire gearbox.
2	Dust seal	(1) Crack or damage (2) Wear	If the outer wall slips, the lip is worn out or damage is found, replace it with a new one.
3	Rack & pinion	Poor mating of rack with pinion	(1) Adjust the backlash properly. By measuring the turning torque of gearbox and sliding resistance of rack, check if rack & pinion engage uniformly and smoothly with each other. (Refer to "Service limit".) (2) Keeping the rack pulled out all the way so that all teeth emerge, check teeth for damage. Even if abnormality is found in either (1) or (2), replace the entire gearbox.
4	Gearbox unit	(1) Bend of rack shaft (2) Bend of cylinder portion (3) Crack or damage on cast iron portion	Replace the gearbox with a new one.
		(4) Wear or damage on rack bush	If the free play of rack shaft in radial direction is out of the specified range, replace the gearbox with a new one. (Refer to "Service limit".)
		(5) Wear on input shaft bearing	If the free plays of input shaft in radial and axial directions are out of the specified ranges, replace the gearbox with a new one. (Refer to "Service limit".)
5	Boot	Crack, damage or deterioration	Replace.
6	Tie-rod	(1) Looseness of ball joint (2) Bend of tie-rod	Replace.
7	Tie-rod end	Damage or deterioration on dust seal	Replace.
8	Adjusting screw spring	Deterioration	Replace.
9	Boot clip	Deterioration	Replace.
10	Sleeve	Damage	Replace.
11	Pipes	(1) Damage to flared surface (2) Damage to flare nut (3) Damage to pipe	Replace.

Steering Gearbox [LHD Model]

POWER ASSISTED SYSTEM (POWER STEERING)

2. SERVICE LIMIT

Make a measurement as follows. If it exceeds the specified service limit, adjust or replace.

NOTE:

When making a measurement, vise the gearbox using ST. Never vise the gearbox by inserting aluminum plates, etc. between vise and gearbox.

ST1 926200000 STAND
ST2 34199AG000 BOSS D

Sliding resistance of rack shaft:

Service limit

400 N (41 kgf, 90 lb) or less

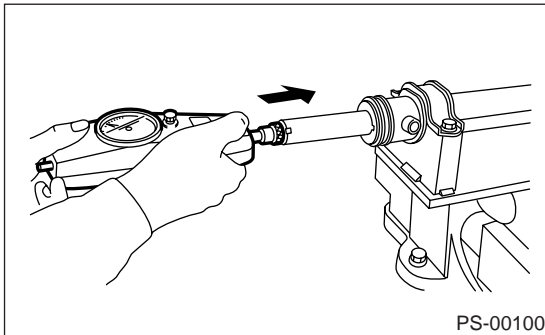
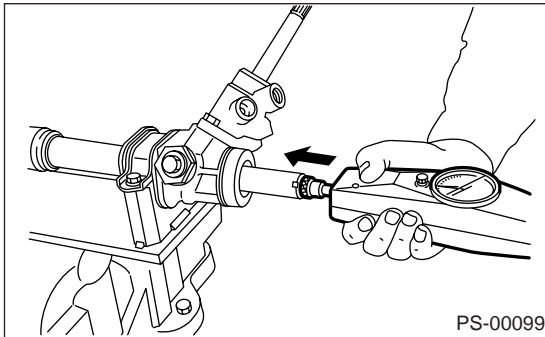

3. RACK SHAFT PLAY IN RADIAL DIRECTION

Right-turn steering:

Service limit

0.19 mm (0.0075 in) or less

On condition

L: 5 mm (0.20 in)

P: 122.6 N (12.5 kgf, 27.6 lb)

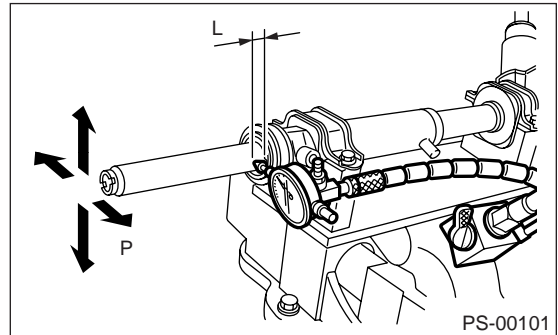

Left-turn steering:

Service limit

Direction $\leftarrow \rightarrow$

0.3 mm (0.012 in) or less

Direction $\leftarrow \rightarrow$

0.15 mm (0.0059 in) or less

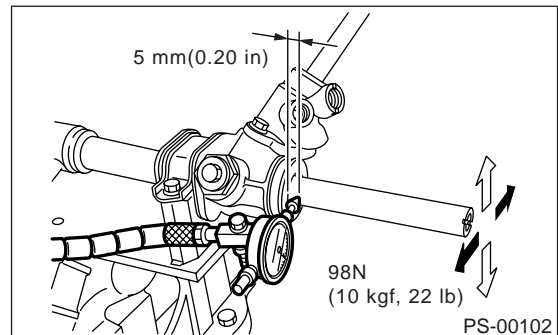

4. INPUT SHAFT PLAY

In radial direction:

Service limit

0.18 mm (0.0071 in) or less

On condition

P: 98 N (10 kgf, 22 lb)

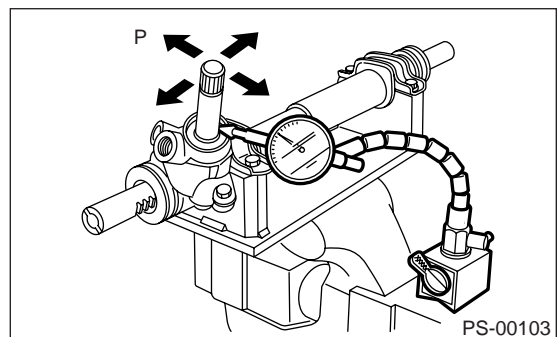

In axial direction:

Service limit

0.5 mm (0.020 in) or less

Steering Gearbox [LHD Model]

POWER ASSISTED SYSTEM (POWER STEERING)

On condition

P: 20 — 49 N (2 — 5 kgf, 4 — 11 lb)

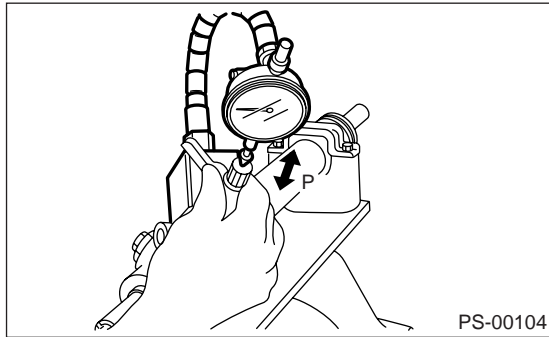

PS-00104

5. TURNING RESISTANCE OF GEARBOX

Using the ST, measure the gearbox turning resistance.

ST 34099PA100 SPANNER

Service limit:

Maximum allowable resistance:

10.5 N (1.1 kgf, 2.4 lb) or less

Difference between right and left turning resistance:

20% or less

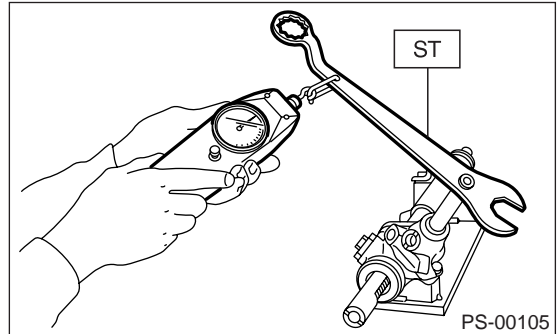

PS-00105

6. OIL LEAKING

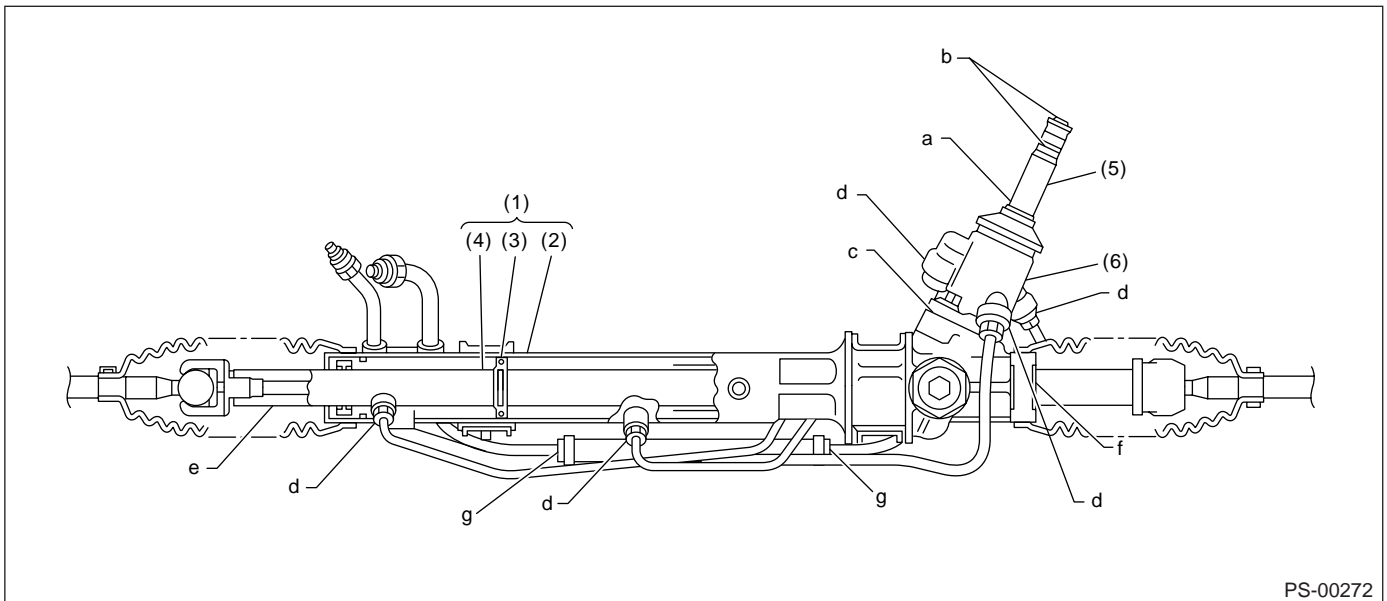

PS-00272

(1) Power cylinder
(2) Cylinder

(3) Rack piston
(4) Rack axle

(5) Input shaft
(6) Valve housing

Steering Gearbox [LHD Model]

POWER ASSISTED SYSTEM (POWER STEERING)

- 1) Lift up the vehicle.
- 2) Even if the location of leak can be easily found by observing the leaking condition, it is necessary to thoroughly remove the fluid from the suspected portion and turn the steering wheel from lock to lock about thirty to forty times with engine running, then make comparison of the suspected portion between immediately after and several hours after this operation.
- 3) Cause and measure for oil leakage from "a"
The oil seal is damaged. Replace the valve assembly with a new one.
- 4) Cause and measure for oil leakage from "b"
The torsion bar O-ring is damaged. Replace the valve assembly with a new one.
- 5) Cause and measure for oil leakage from "c"
The oil seal is damaged. Replace the valve assembly or oil seal with a new one.
- 6) Cause and measure for oil leakage from "d"
The pipe is damaged. Replace the faulty pipe or O-ring.
- 7) Cause and measure for oil leakage from "g"
The hose is damaged. Replace the hose with a new one.
- 8) If leak is other than a, b, c, d, or g, and if oil is leaking from the gearbox, move the right and left boots toward tie-rod end side, respectively, with the gearbox mounted to the vehicle, and remove fluid from the surrounding portions. Then, turn the steering wheel from lock to lock thirty to forty times with the engine running, and make comparison of the leaked portion immediately after and several hours after this operation.

(1) Leakage from "e"

The cylinder seal is damaged. Replace the rack bush with a new one.

(2) Leakage from "f"

There are two possible causes. Take the following step first. Remove the pipe assembly B from the valve housing, and close the circuit with ST.

ST 926420000 PLUG

Turn the steering wheel from lock to lock thirty to forty times with the engine running, then make comparison of the leaked portion between immediately after and several hours after this operation.

- If leakage from "f" is noted again:

The oil seal of pinion & valve assembly is damaged. Replace the pinion & valve assembly with a new one. Or replace the oil seal and parts that are damaged during disassembly with new ones.

- If oil stops leaking from "f":

The oil seal of rack housing is damaged. Replace the oil seal and the parts that are damaged during disassembly with new ones.

F: ADJUSTMENT

- 1) Adjust the front toe. <Ref. to FS-12, FRONT WHEEL TOE-IN, INSPECTION, Wheel Alignment.>

Standard of front toe:

IN 3 — OUT 3 mm (IN 0.12 — OUT 0.12 in)

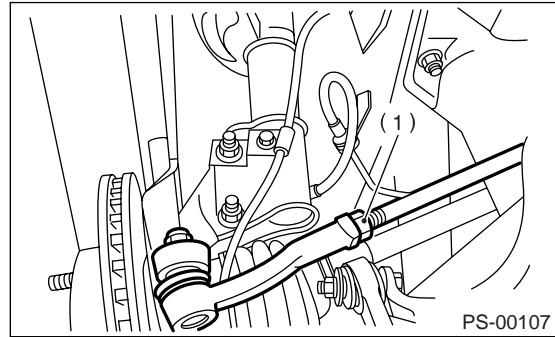

(1) Lock nut

- 2) Adjust the steering angle of wheels.

Standard of steering angle:

Model	2.0 i, 2.5 i	3.0 R	OUTBACK
Inner wheel	37.3°±1.5°	37.2°±1.5°	37.8°±1.5°
Outer wheel	33.0°±1.5°	32.9°±1.5°	33.5°±1.5°

- 3) If the steering wheel spokes are not horizontal when wheels are set in the straight ahead position, and error is more than 5° on the periphery of steering wheel, correctly re-install the steering wheel.

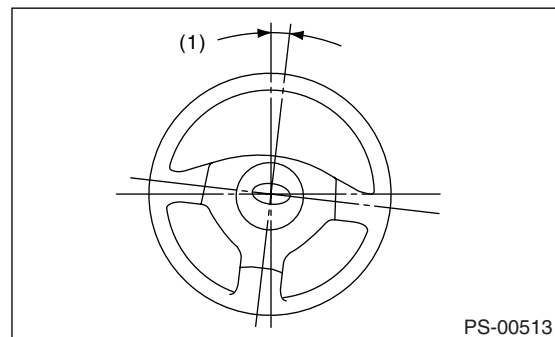

(1) Within 5°

- 4) If the steering wheel spokes are not horizontal with vehicle set in the straight ahead position after this adjustment, correct it by turning the right and left tie-rods in opposite direction by same angle.

Steering Gearbox [RHD Model]

POWER ASSISTED SYSTEM (POWER STEERING)

6. Steering Gearbox [RHD Model]

A: REMOVAL

- 1) Set the vehicle on a lift.
- 2) Disconnect the ground cable from battery.
- 3) Loosen the front wheel nuts.
- 4) Lift-up the vehicle and remove the front wheels.
- 5) Remove the under cover. <Ref. to EI-26, REMOVAL, Front Under Cover.>
- 6) Remove the front exhaust pipe assembly. (Non-turbo model) <Ref. to EX(H4SO 2.0)-7, REMOVAL, Front Exhaust Pipe.>

WARNING:

Be careful, not to burn your hand because the exhaust pipe is hot.

- 7) Using a puller, remove the tie-rod end from the knuckle arm after pulling off cotter pin and removing castle nut.

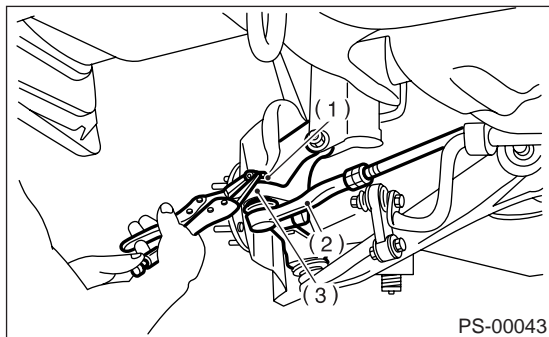

- (1) Castle nut
- (2) Tie-rod end
- (3) Knuckle arm

- 8) Remove the front crossmember support plate, jack-up plate and front stabilizer. <Ref. to FS-16, REMOVAL, Front Stabilizer.>

• Large type

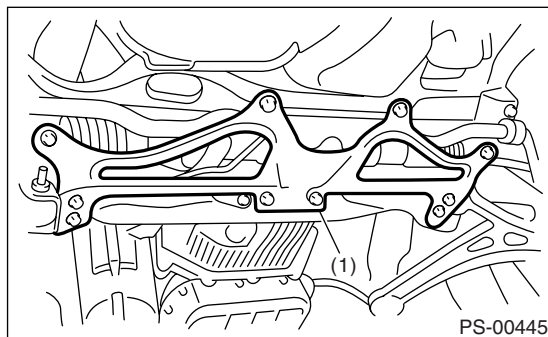

- (1) Front crossmember support plate

• Small type

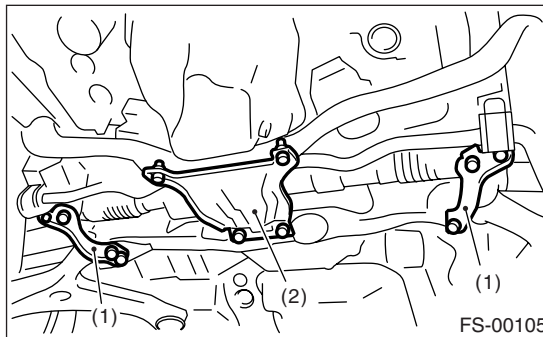

- (1) Front crossmember support plate
- (2) Jack-up plate

- 9) Remove the one pipe joint at the center of gearbox, and connect the vinyl hose to the pipe and the joint. Discharge the fluid by turning steering wheel fully clockwise and counterclockwise. Discharge the fluid similarly from other pipes.

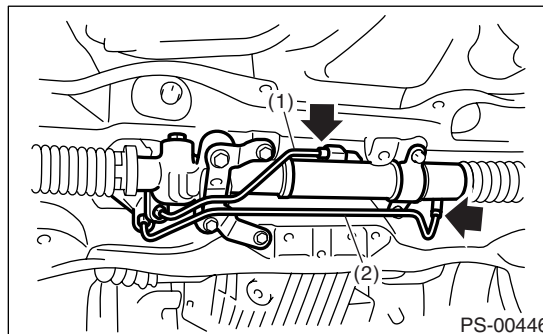

- (1) Pipe A
- (2) Pipe B

- 10) Remove the universal joint. <Ref. to PS-21, REMOVAL, Universal Joint.>

Steering Gearbox [RHD Model]

POWER ASSISTED SYSTEM (POWER STEERING)

11) Disconnect the return hose and pressure hose from gearbox.

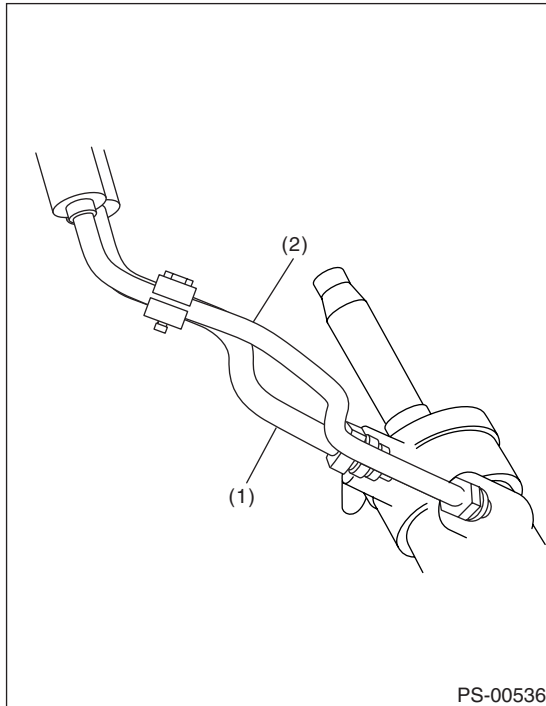

- (1) Return hose
- (2) Pressure hose

12) Remove the clamp bolts securing gearbox to crossmember, and remove the clamp.

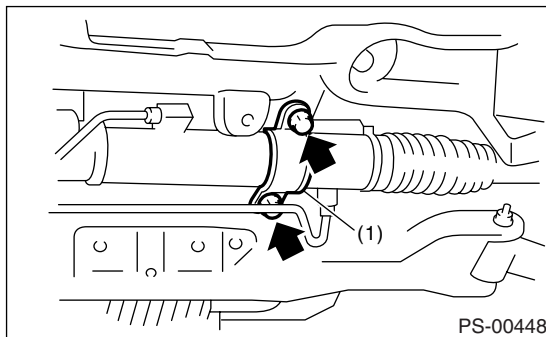

- (1) Clamp

13) Remove the bolts which secure the gearbox bracket, and remove the bracket and gearbox.

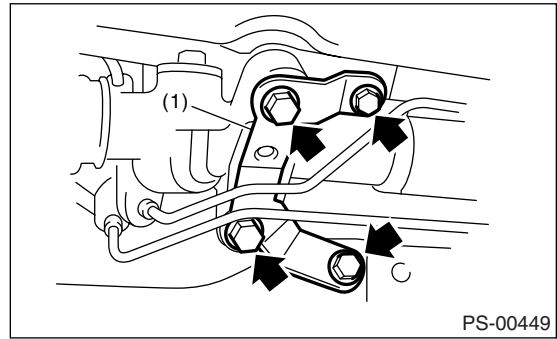

- (1) Bracket

B: INSTALLATION

1) Insert the gearbox into the crossmember, being careful not to damage gearbox boot.

2) Install the gearbox and bracket. Tighten the bolt temporarily.

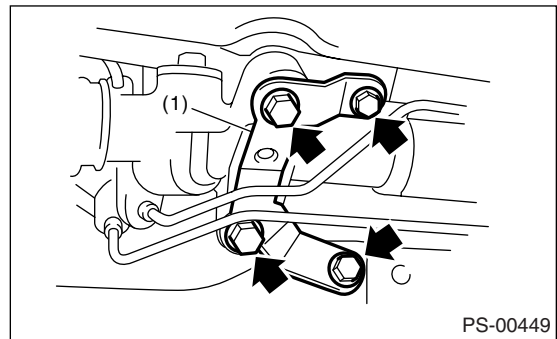

- (1) Bracket

3) Tighten the gearbox to the crossmember bracket via clamp with bolt temporarily.

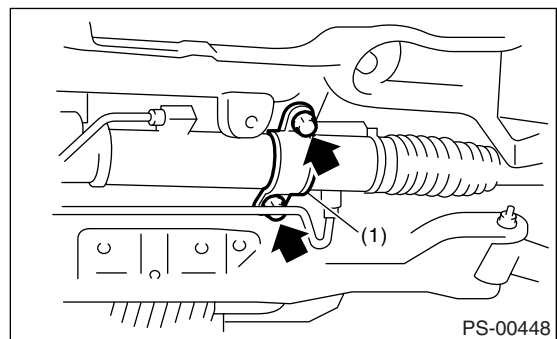

- (1) Clamp

4) Tighten the bolts which temporary tightening the clamp and bracket of gearbox to specified torque.

Tightening torque:

60 N·m (6.1 kgf·m, 44.1 ft·lb)

Steering Gearbox [RHD Model]

POWER ASSISTED SYSTEM (POWER STEERING)

5) Connect the return hose and pressure hose to gearbox.

Tightening torque:

15 N·m (1.5 kgf·m, 10.8 ft·lb)

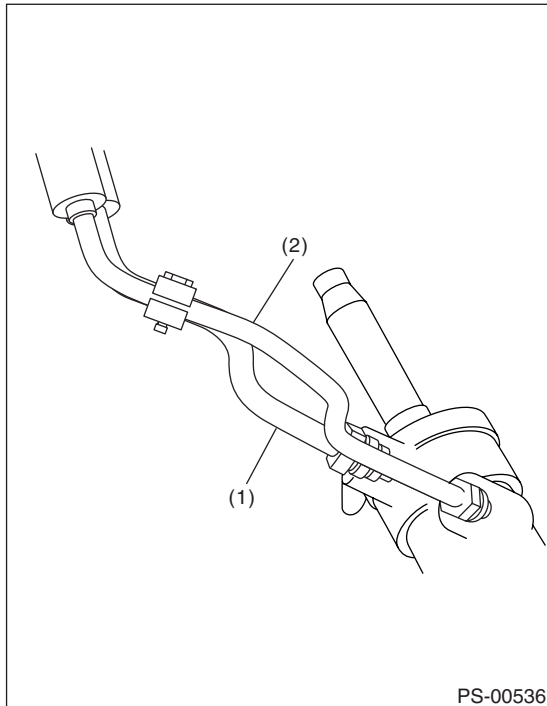

- (1) Return hose
- (2) Pressure hose

6) Install the universal joint. <Ref. to PS-21, INSTALLATION, Universal Joint.>

7) Connect the tie-rod end and knuckle arm, and tighten with castle nut.

Castle nut tightening torque:

27 N·m (2.75 kgf·m, 19.9 ft·lb)

CAUTION:

When connecting, do not hit cap at the bottom of tie-rod end with hammer.

8) After tightening the castle nut to specified tightening torque, tighten it further within 60° until cotter pin hole is aligned with slot in the nut. Fit the cotter pin into nut, and then bend the pin to lock.

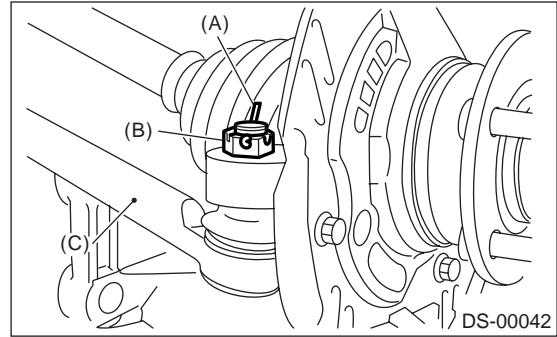

- (A) Cotter pin
- (B) Castle nut
- (C) Tie-rod end

9) Install the front stabilizer. <Ref. to FS-16, INSTALLATION, Front Stabilizer.>

10) Install the front crossmember support plate and jack-up plate.

11) Install the front exhaust pipe assembly. (Non-turbo model) <Ref. to EX(H4SO 2.0)-8, INSTALLATION, Front Exhaust Pipe.>

12) Install the under cover. <Ref. to EI-26, INSTALLATION, Front Under Cover.>

13) Install the front wheels.

14) Tighten the wheel nuts to specified torque.

Tightening torque:

90 N·m (9.1 kgf·m, 65.8 ft·lb)

15) Lower the vehicle.

16) Remove the steering wheel. <Ref. to PS-20, REMOVAL, Steering Wheel.>

17) Align the center of roll connector. <Ref. to AB-23, ADJUSTMENT, Roll Connector.>

18) Install the steering wheel. <Ref. to PS-20, INSTALLATION, Steering Wheel.>

19) Connect the battery ground cable to battery.

20) Pour fluid into the oil tank, and bleed air. <Ref. to PS-84, Power Steering Fluid.>

21) Check for fluid leaks.

22) Check the fluid level in oil tank.

23) After adjusting toe-in and steering angle, tighten the lock nut on tie-rod end.

Tightening torque:

85 N·m (8.7 kgf·m, 62.7 ft·lb)

Steering Gearbox [RHD Model]

POWER ASSISTED SYSTEM (POWER STEERING)

NOTE:

When adjusting toe-in, hold the boot as shown to prevent it from being rotated or twisted. If twisted, straighten it.

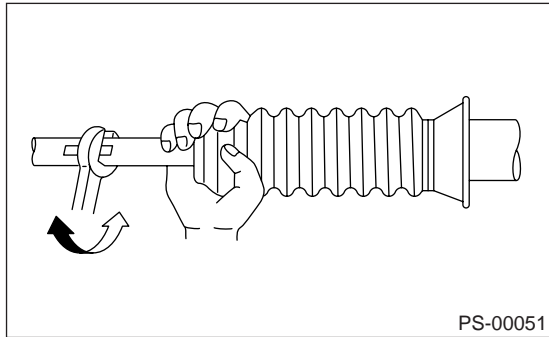

3) Remove the tie-rod end and lock nut from gearbox.

4) Remove the clip from outside boot using pliers, and then move the boot to tie-rod end side.

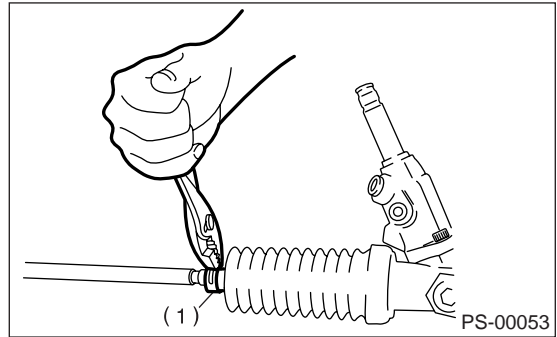

(1) Clip

C: DISASSEMBLY

1) Disconnect the pipes A and B from steering body and control valve housing.

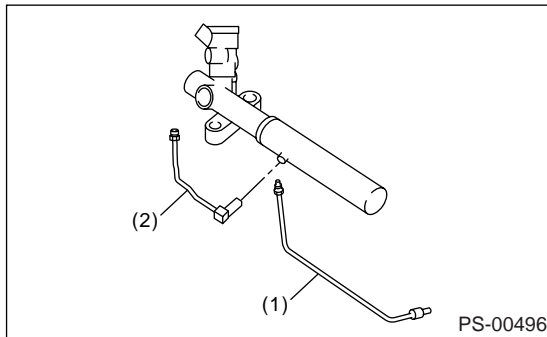

(1) Pipe A
(2) Pipe B

5) Using a flat tip screwdriver, remove the band from boot.

NOTE:

Replace the boot if there is damage, cracks or deterioration.

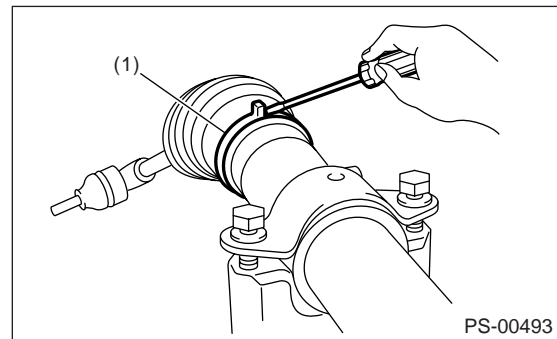

(1) Band

2) Secure the gearbox removed from vehicle in a vice using ST.

ST1 926200000 STAND

ST2 34199AG000 BOSS D

CAUTION:

Secure the gearbox assembly in a vice using the ST as shown. Do not secure the gearbox without this ST.

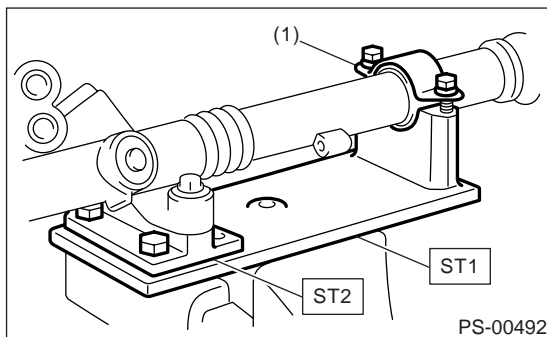

(1) Clamp

6) Using the ST, loosen the lock nut.

ST 926230000 SPANNER

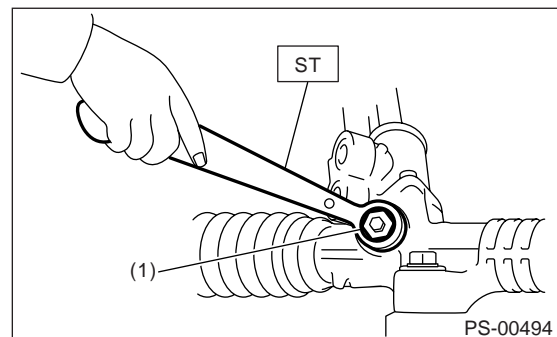

(1) Lock nuts

Steering Gearbox [RHD Model]

POWER ASSISTED SYSTEM (POWER STEERING)

7) Tighten the adjusting screw until it no longer tightens.

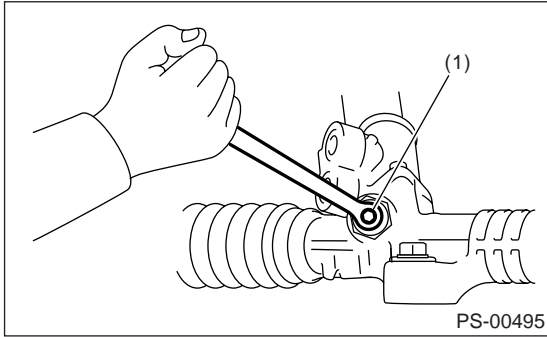

(1) Adjusting screw

8) Using a 32 mm spanner or adjustable wrench with cinching boot, remove the tie-rod.

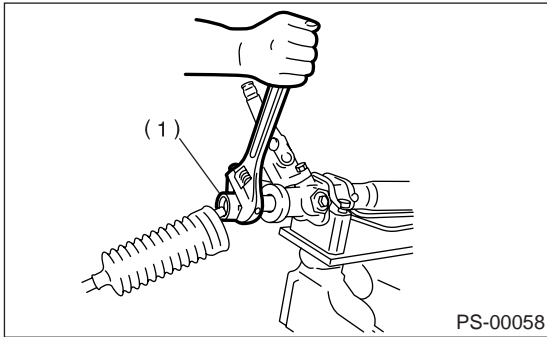

(1) Tie-rod

9) Loosen the adjusting screw and remove the spring and sleeve.

10) Clean the dirt adherent to the input shaft. Remove the dust cover paying attention not to scratch the housing or input shaft and not to allow foreign matter to enter the gear box interior.

CAUTION:

Wrap the tape to the spline part of input shaft to avoid damaging dust cover.

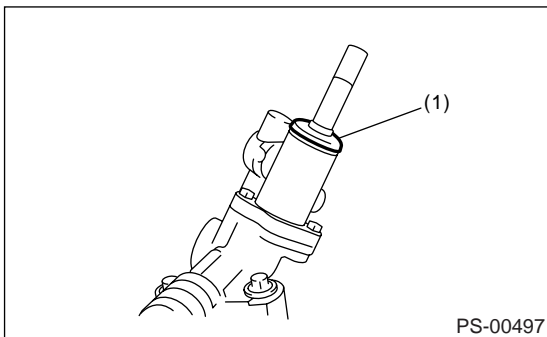

(1) Dust cover

11) Align the ST pin with the plug hole to install. Rotate the ST counterclockwise to remove the plug.

ST 34199AE090 PLUG WRENCH

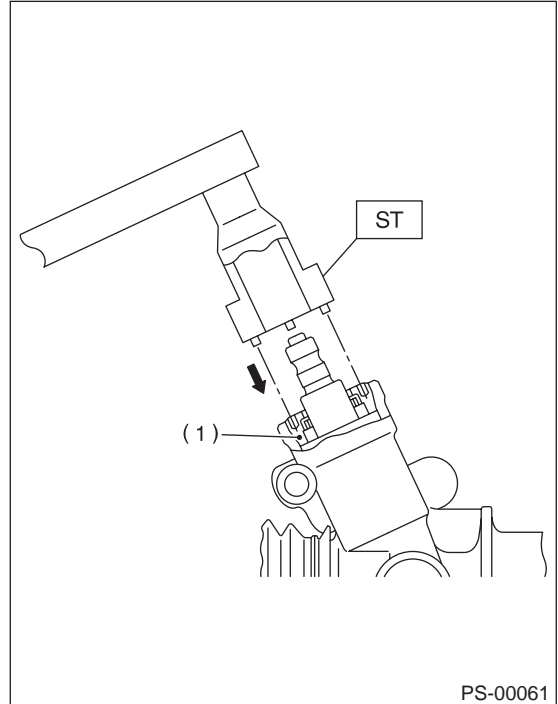

(1) Plug

12) Remove the valve assembly paying attention not to scratch seal ring or valve housing inner surface.

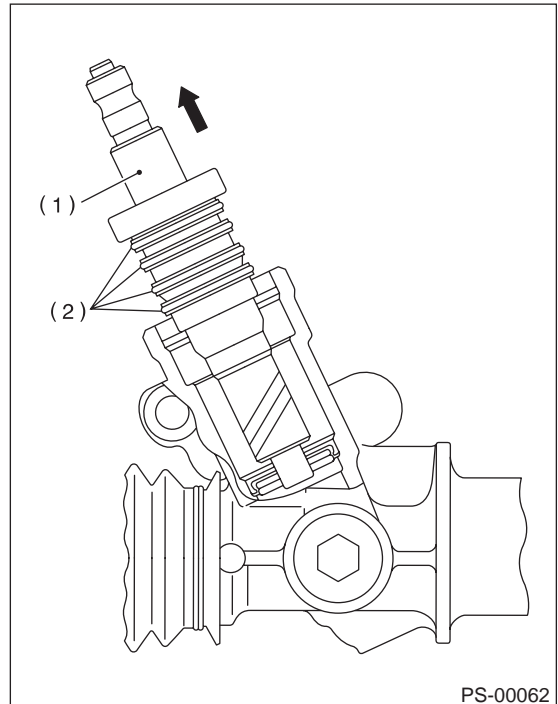

(1) Valve ASSY

(2) Seal ring

Steering Gearbox [RHD Model]

POWER ASSISTED SYSTEM (POWER STEERING)

13) Remove the holder using a 36 mm spanner or adjustable wrench.

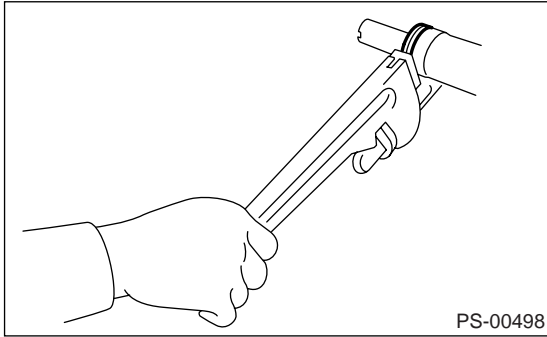

14) Install the ST on valve side of rack and press outer side oil seal out taking care not to contact rack with steering body inner surface.

ST 34199FE010 INSTALLER & REMOVER (Turbo and 3.0 R model)

ST 34199FA030 INSTALLER & REMOVER (Except for turbo and 3.0 R model)

NOTE:

Block the pipe connection of steering body to prevent fluid from flowing out.

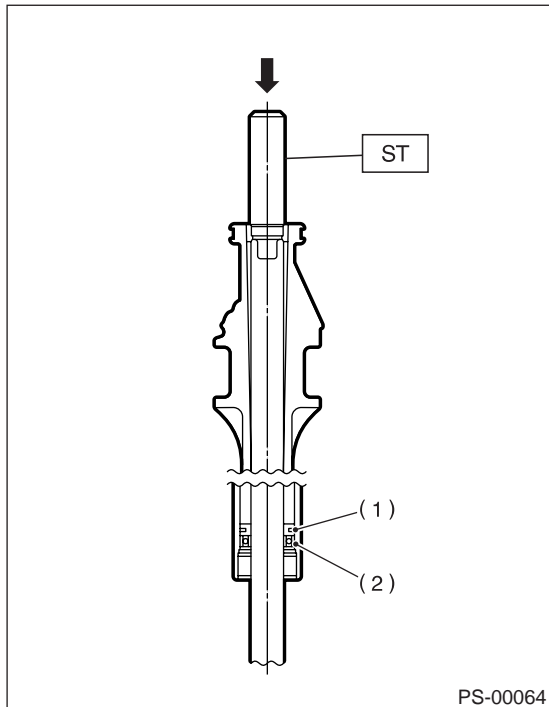

- (1) Rack piston
- (2) Outer side oil seal

15) Insert the ST from the valve side and press the back-up ring and oil seal out.

ST 34199FE010 REMOVER (Turbo and 3.0 R model)

ST 927580000 REMOVER (Except for turbo and 3.0 R model)

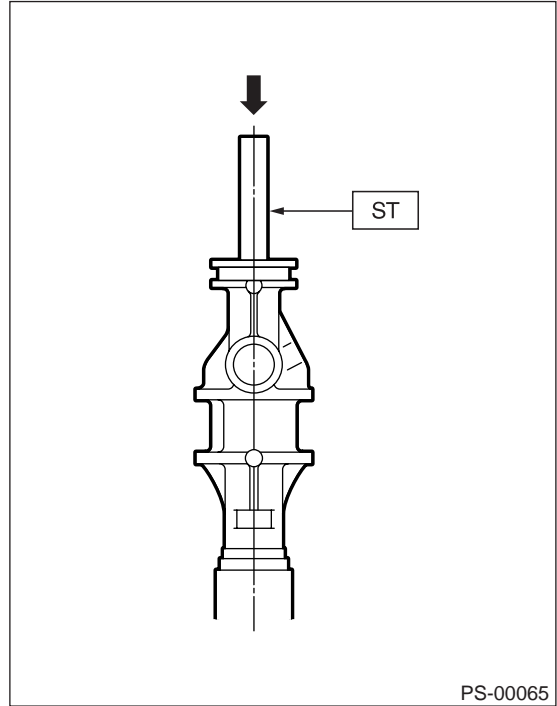

Steering Gearbox [RHD Model]

POWER ASSISTED SYSTEM (POWER STEERING)

16) Using ST1 and ST2, repair the caulking portion of cylinder.

ST1 34099FA080 PUNCH

ST2 34199FE020 BASE (Turbo and 3.0 R model)

ST2 34099FA070 BASE (Except for turbo and 3.0 R model)

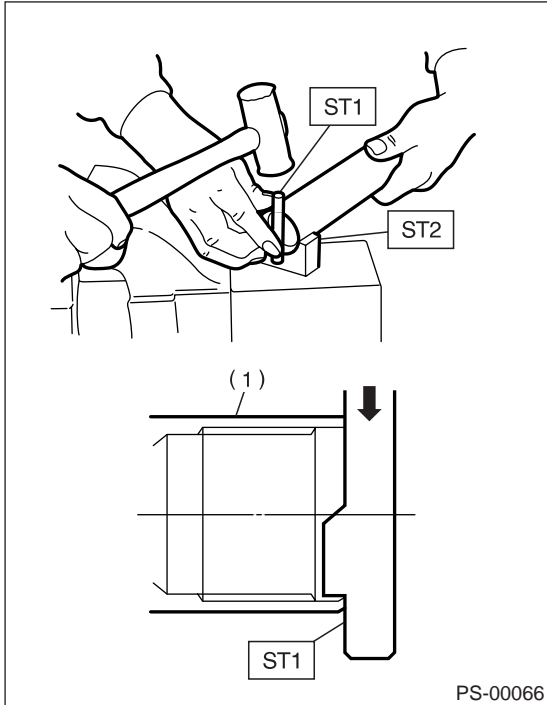

(1) Cylinder

17) If the cylinder edge is deformed in a convex shape, repair using an oil stone.

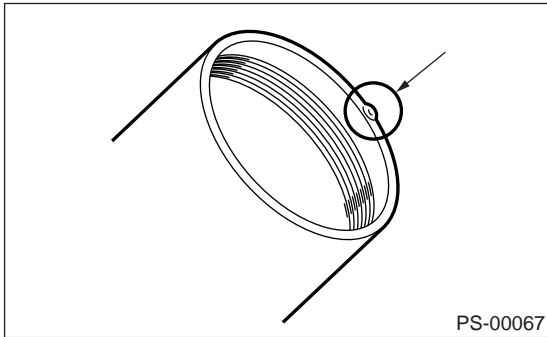

18) Remove the oil seal using ST and press from plug.

ST 34199AE100 OIL SEAL PLUG REMOVER

NOTE:

Do not apply force on the plug edge surface.

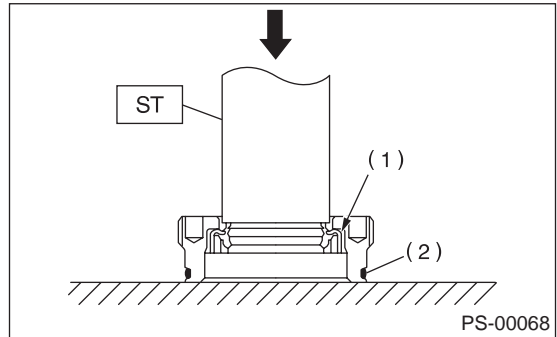

(1) Oil seal

(2) O-ring

19) Set the ST in the dimension as shown in the figure.

ST 34199AE120 GEARBOX OIL SEAL REMOVER

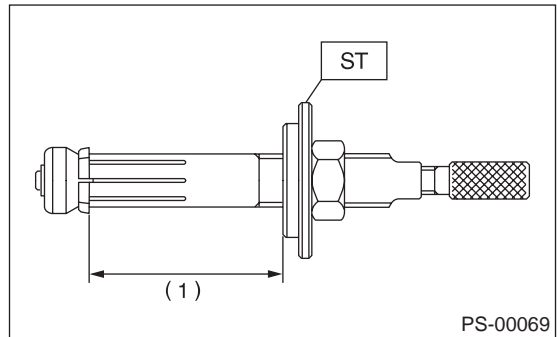

(1) 70 mm (2.76 in)

Steering Gearbox [RHD Model]

POWER ASSISTED SYSTEM (POWER STEERING)

20) Set the stopper to gearbox, and then insert the tip of ST to gearbox.

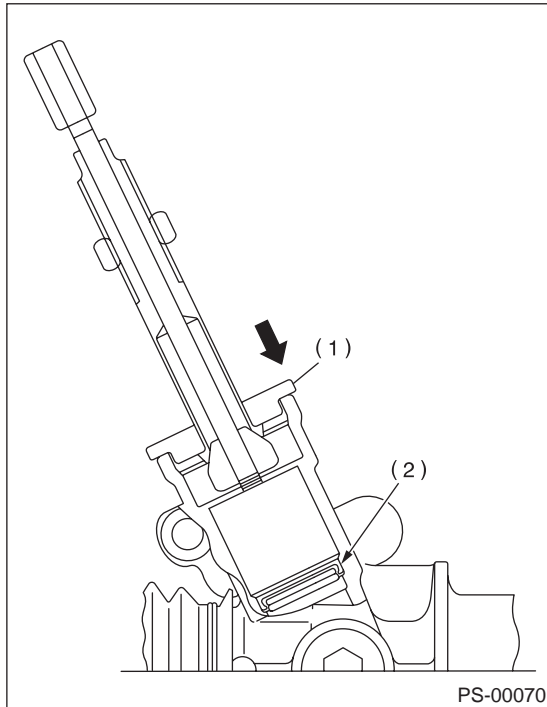

- (1) Stopper
- (2) Oil seal

21) By fixing the 2-surface width, press-in by rotating the rod and attach to oil seal.

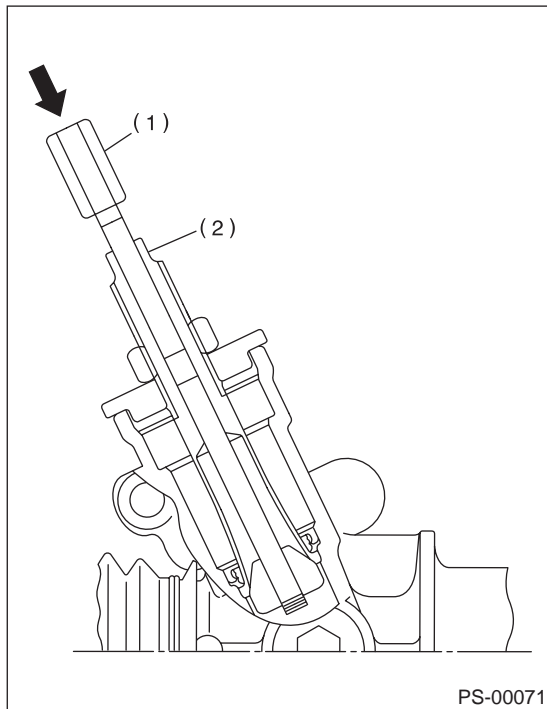

- (1) Rod
- (2) 2-surface width

22) While fixing the 2-surface width, pull out the oil seal by rotating nut.

CAUTION:

Take care not to scratch the gearbox inner surface.

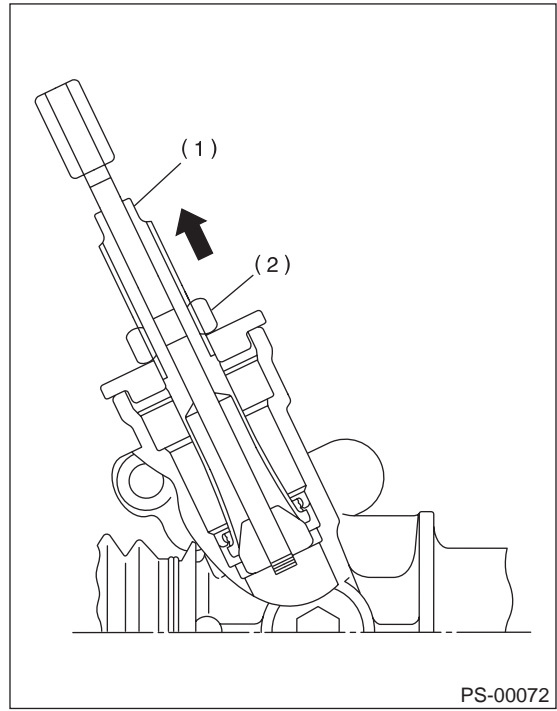

- (1) 2-surface width
- (2) Nut

D: ASSEMBLY

1) Apply a coat of grease to the inside and outside of new oil seal.

Steering grease:

VALIANT GREASE M2 (Part No. 003608001)

2) Verify the oil seal direction and installation position. Using the ST and press, press-fit the oil seal to gearbox.

ST 34199AE130 GEARBOX OIL SEAL INSTALLER

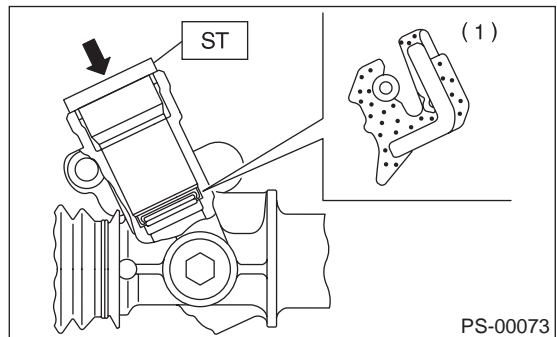

- (1) Oil seal

Steering Gearbox [RHD Model]

POWER ASSISTED SYSTEM (POWER STEERING)

3) Attach the steering body to ST as shown in the figure. Apply a coat of grease to needle bearing.

ST1 926200000 STAND
ST2 34199AG000 BOSS D

CAUTION:

Ensure the needle bearing is free from defects. If it is faulty, replace the steering body with a new one.

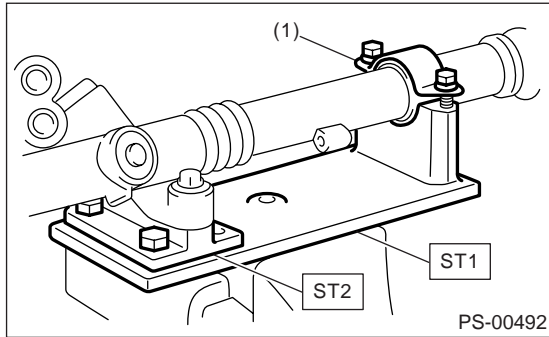

(1) Clamp

4) Using ST-B and ST-C, install the oil seal to ST-A.

ST 34199FE040 INSTALLER A, B, C (Turbo and 3.0 R model)

ST 927490000 INSTALLER A, B, C (Except for turbo and 3.0 R model)

NOTE:

Face the oil seal in the direction as shown in the figure.

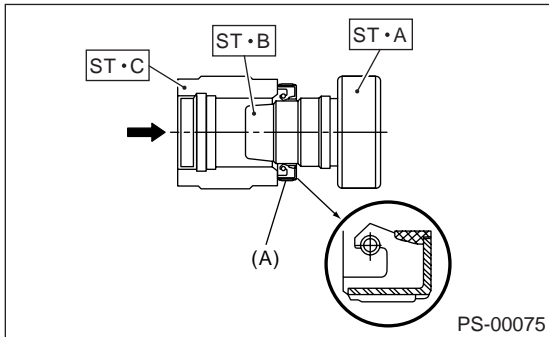

(A) Oil seal

5) Insert the ST-A with oil seal assembled from the gear side of rack. Remove the oil seal from ST-A near piston, and then remove the ST-A from rack.

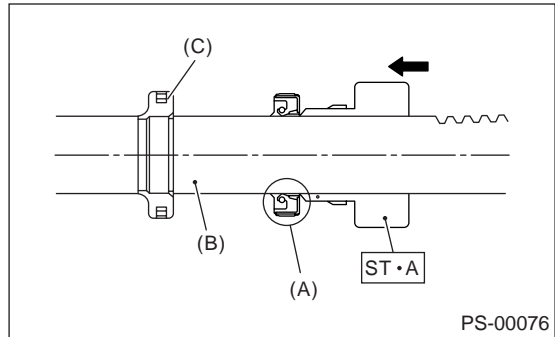

(A) Oil seal
(B) Rack
(C) Piston

6) Install the back-up washer from gear side of rack.

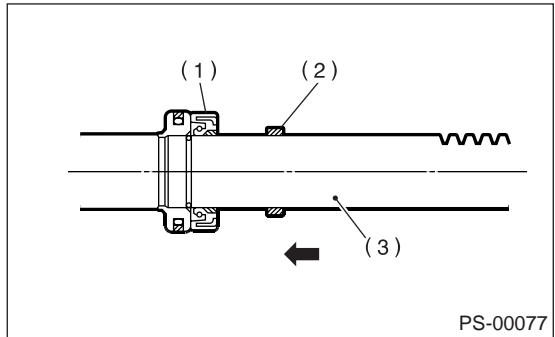

(1) Oil seal
(2) Back-up washer
(3) Rack

7) Install the ST on rack, and equally apply a thin coat of grease to the rack and ST, then install the oil seal.

ST 926250000 GUIDE

CAUTION:

Be careful not to scratch the oil seal lips with the inner ring section of piston.

Steering Gearbox [RHD Model]

POWER ASSISTED SYSTEM (POWER STEERING)

NOTE:

Do not use this ST for turbo model.

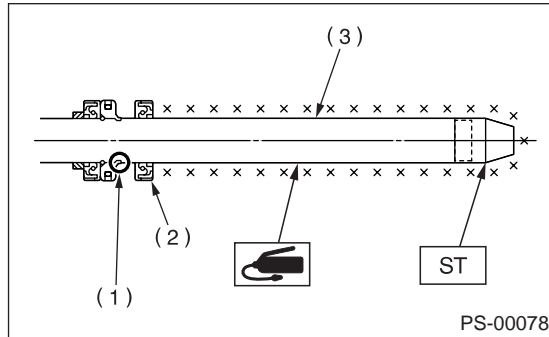

- (1) Rack piston inner ring
- (2) Outer side oil seal
- (3) Rack

8) Apply a coat of grease to the grooves in rack, sliding surface of sleeve and sealing surface of piston. Install ST on the end of steering body cylinder. Then insert the rack into steering body from cylinder side.

ST 34199FE050 GUIDE (Turbo and 3.0 R model)

ST 34199AE000 GUIDE (Except for turbo and 3.0 R model)

CAUTION:

Do not allow grease to block the air vent hole on rack.

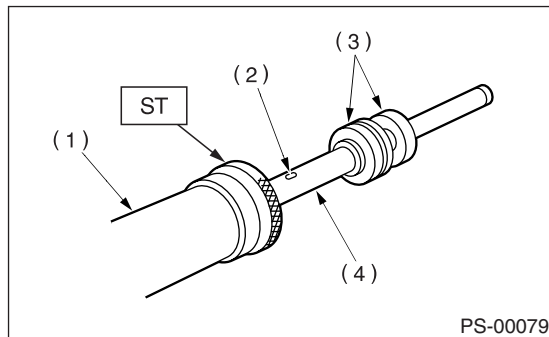

- (1) Cylinder side of steering body
- (2) Air vent hole
- (3) Oil seal
- (4) Rack

9) Make the ST2 pass through rack, and then press-in the rack and ST2 using press. Press-in the rack until ST1 comes in contact with ST2 and the edge surface of rack is aligned with that of ST2.

ST1 34199FE050 GUIDE (Turbo and 3.0 R model)

34199AE000 GUIDE (Except for turbo and 3.0 R model)

ST2 34199FE060 INSTALLER (Turbo and 3.0 R model)

34199AE010 INSTALLER (Except for turbo and 3.0 R model)

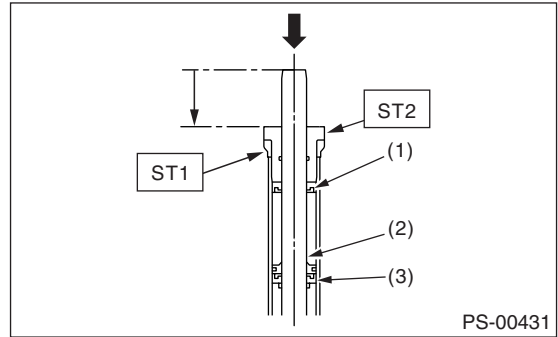

- (1) Outer side oil seal
- (2) Rack piston
- (3) Inner side oil seal

10) Install a new holder to the cylinder side of steering body.

Tightening torque:

Turbo and 3.0 R model

90 N·m (9.18 kgf-m, 66.4 ft-lb)

Except for turbo and 3.0 R model

64 N·m (6.5 kgf-m, 47.0 ft-lb)

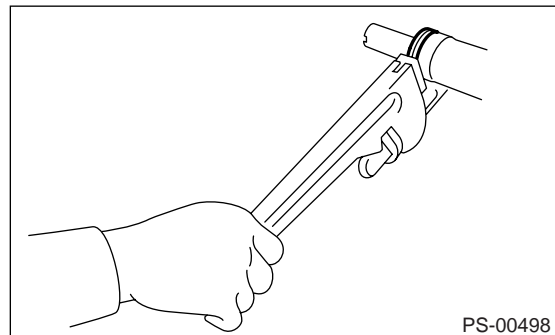

11) Using the ST, caulk the steering body at one point less than 3mm (0.12 in) from holder.

CAUTION:

Be careful not to deform the holder.

Steering Gearbox [RHD Model]

POWER ASSISTED SYSTEM (POWER STEERING)

ST 34099FA060 PUNCH HOLDER

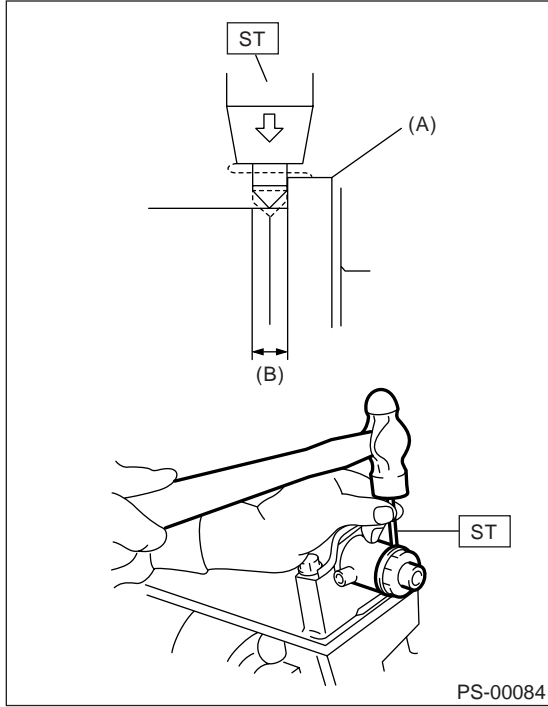

- (A) Holder
- (B) 3 mm (0.12 in)

12) Roll the vinyl tape on serration part of valve assembly, and then apply grease on the tape surface.

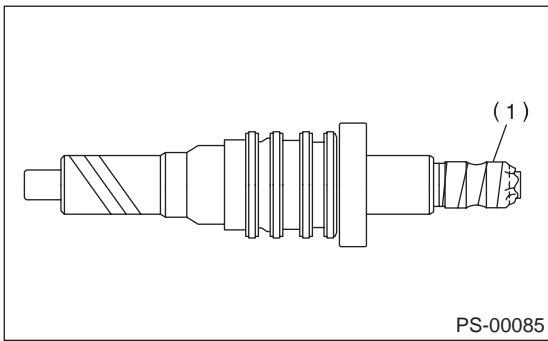

- (1) Vinyl tape

13) Apply a coat of grease on the gear teeth of valve assembly, and then attach the valve assembly taking care not to scratch oil seal and seal ring.

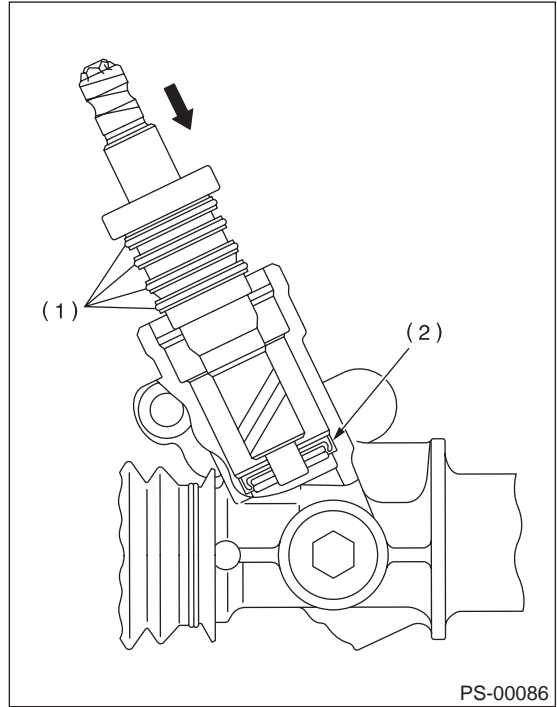

- (1) Seal ring
- (2) Oil seal

14) Apply grease on the oil seal circumference, and then press it into the plug using ST and press. Replace the O-rings of plug circumference with new ones.

ST 34199AE110 OIL SEAL PLUG INSTALLER

CAUTION:
Install the oil seal paying attention to its direction.

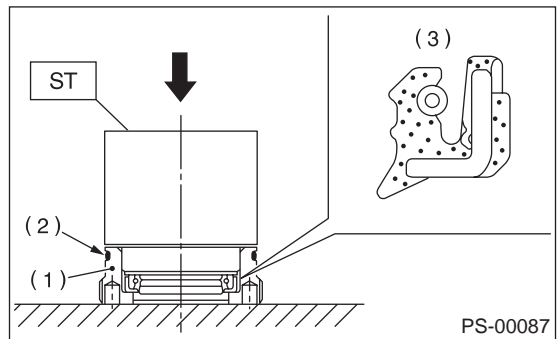

- (1) Plug
- (2) O-ring
- (3) Oil seal

Steering Gearbox [RHD Model]

POWER ASSISTED SYSTEM (POWER STEERING)

15) Using the ST, install plug.
ST 34199AE090 PLUG WRENCH

Tightening torque:

64 N·m (6.5 kgf·m, 47.0 ft·lb)

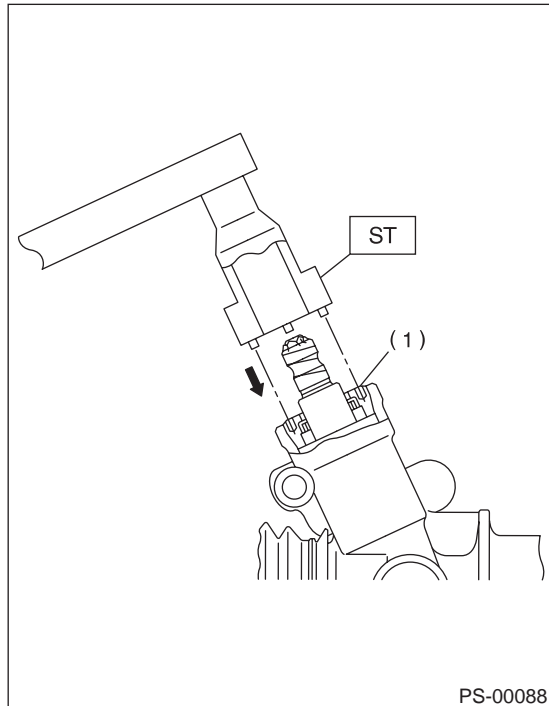

(1) Plug

16) Install the dust cover. Remove the vinyl tape.

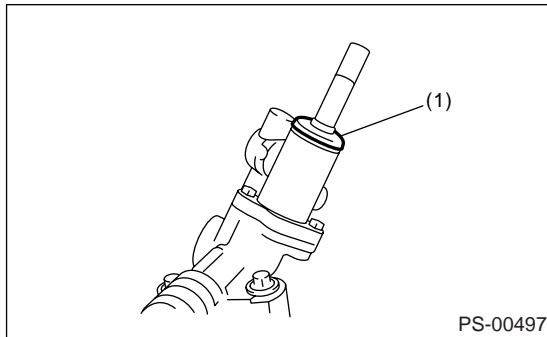

(1) Dust cover

17) Temporarily install the tie-rod to the rack, and then operate it from lock to lock two or three times to make it fit in. Remove the grease blocking air vent hole.

CAUTION:

If operating the rack from lock to lock without installing tie-rod, it may damage the oil seal. Always install the tie-rods LH and RH.

18) Apply a coat of grease to the sliding surface of sleeve and seating surface of spring, and then insert the sleeve into spring body.

Charge the adjusting screw with grease, and then insert the spring into adjusting screw and install on steering body.

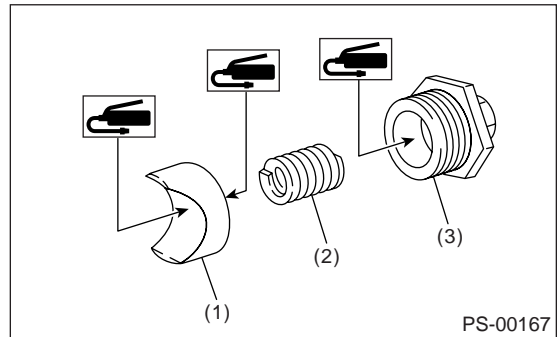

- (1) Sleeve
- (2) Spring
- (3) Adjusting screw

19) Tighten the adjusting screw to specified torque.

Tightening torque:

9.8 N·m (1.0 kgf·m, 7.2 ft·lb)

20) After tightening the adjusting screw with the specified tightening torque, loosen it.

Tightening torque:

4.9 N·m (0.50 kgf·m, 3.6 ft·lb)

21) After tightening the adjusting screw with the specified tightening torque, loosen 37° it.

Tightening torque:

4.9 N·m (0.50 kgf·m, 3.6 ft·lb)

22) Remove the tie-rod.

23) Verify that play is within specified value. <Ref. to PS-61, LIMIT, INSPECTION, Steering Gearbox [RHD Model].>

24) Loosen the adjusting screw, and then apply liquid gasket to at least 1/3 of the entire perimeter of adjusting screw thread.

Liquid gasket:

THREE BOND 1141 (Part No. 004403006)

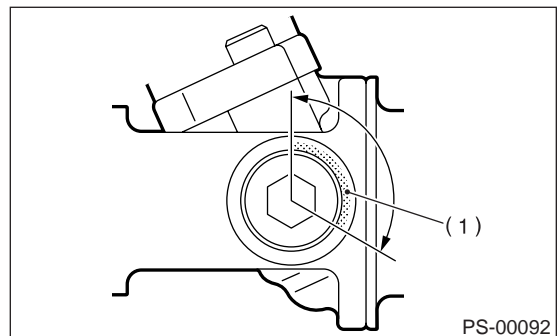

- (1) Apply liquid gasket to at least 1/3 of entire perimeter.

Steering Gearbox [RHD Model]

POWER ASSISTED SYSTEM (POWER STEERING)

25) Install the lock nut. While holding adjusting screw with a wrench, tighten the lock nut using ST. ST 926230000 SPANNER

Tightening torque (Lock nut):
39 N·m (4.0 kgf·m, 28.9 ft·lb)

NOTE:
Hold the adjusting screw with a wrench to prevent it from turning while tightening lock nut.

26) Install the tie-rod into rack.

Tightening torque:
90 N·m (9.0 kgf·m, 65.1 ft·lb)

NOTE:
Check the mating face of rack and tie-rod for foreign material, dirt and etc.

27) Apply a coat of grease to the tie-rod groove, and then install the boot to housing.

NOTE:
Make sure that the boot is installed without unusual inflation or deflation.

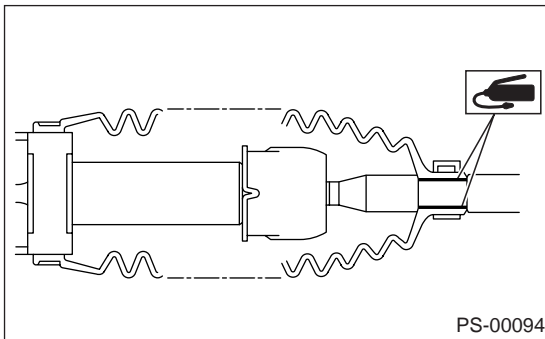

28) Caulk the boot so the space inside boot band caulking portion becomes 2 mm (0.08 in) or less.

NOTE:
Use a new boot band.

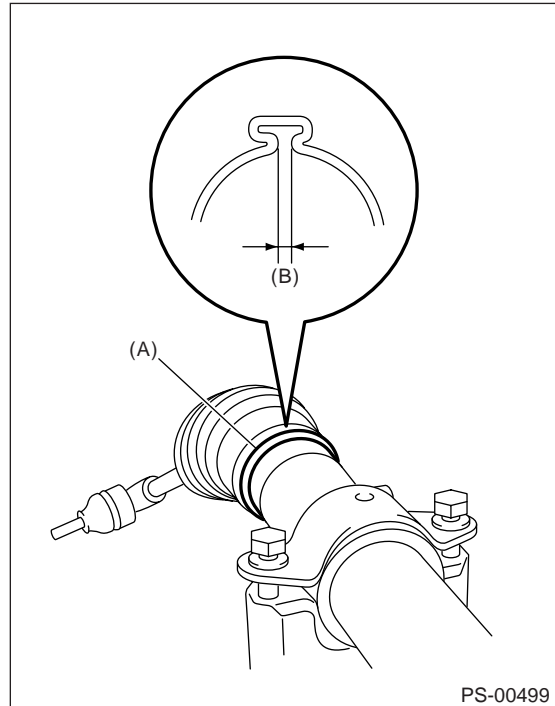

- (A) Boot band
- (B) 2 mm (0.08 in) or less

29) Fix the boot end with clip (small).

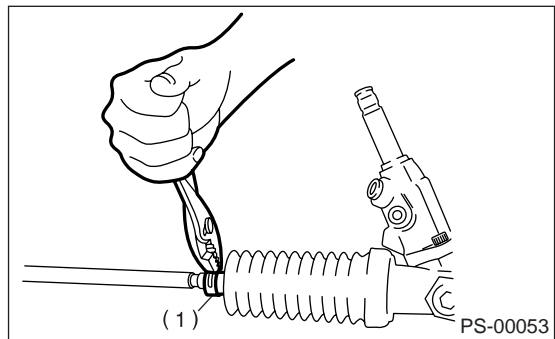

- (1) Clip

30) After installing, check that the boot end is positioned into groove on tie-rod.

31) If the tie-rod end has been removed, screw in lock nut and tie-rod end to the screwed portion of tie-rod, and tighten the lock nut temporarily in a position as shown in figure.

Steering Gearbox [RHD Model]

POWER ASSISTED SYSTEM (POWER STEERING)

Installed tie-rod length L:
31 mm (1.22 in)

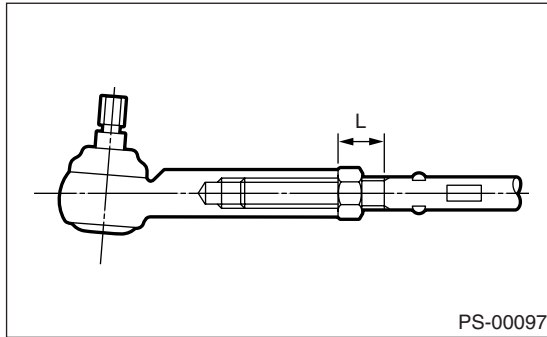

32) Inspect the gearbox as follows:
"A" Holding tie-rod end, repeat lock to lock two or three times as quickly as possible.
"B" Holding tie-rod end, turn it slowly at a radius one or two times as large as possible.
After all, make sure that the boot is installed in the specified position without deflation.

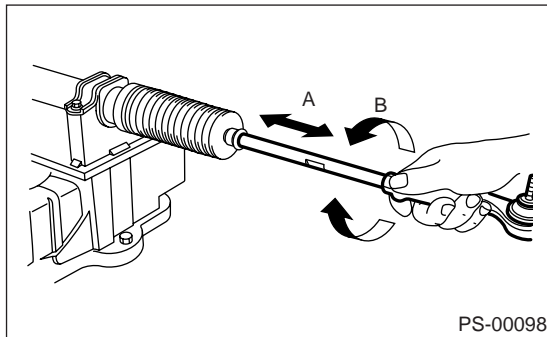

33) Take off the gearbox from ST.
ST1 926200000 STAND
ST2 34199AG000 BOSS D
34) Install the pipe A and B to steering body and control valve housing.

Tightening torque:
T1: 20 N·m (2.0 kgf-m, 14.5 ft-lb)
T2: 24 N·m (2.4 kgf-m, 17.4 ft-lb)

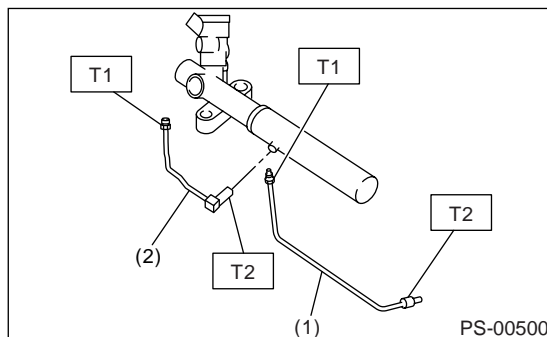

- (1) Pipe A
- (2) Pipe B

Steering Gearbox [RHD Model]

POWER ASSISTED SYSTEM (POWER STEERING)

E: INSPECTION

1. BASIC INSPECTION

1) Clean all disassembled parts, and check for wear, damage or any other faults, then repair or replace as necessary.

2) When disassembling, check inside of gearbox for water. If any water is found, carefully check boot for damage, input shaft dust seal, adjusting screw and boot clips for poor sealing. If faulty, replace with new parts.

No.	Parts	INSPECTION	Corrective action
1	Input shaft	(1) Bend of input shaft (2) Damage on serration	If the bend or damage is excessive, replace the entire gearbox.
2	Dust seal	(1) Crack or damage (2) Wear	If the outer wall slips, the lip is worn out or damage is found, replace it with a new one.
3	Rack & Pinion	Poor mating of rack with pinion	(1) Adjust the backlash properly. By measuring turning torque of gearbox and sliding resistance of rack, check if rack & pinion engage uniformly and smoothly with each other. (Refer to "Service limit".) (2) Keeping rack pulled out all the way so that all teeth emerge, check teeth for damage. Even if abnormality is found in either (1) or (2), replace the entire gearbox.
4	Gearbox unit	(1) Bend of rack shaft (2) Bend of cylinder portion (3) Crack or damage on cast iron portion	Replace the gearbox with a new one.
		(4) Wear or damage on rack bush	If the free play of rack shaft in radial direction is out of the specified range, replace the gearbox with new one. (Refer to "Service limit".)
		(5) Wear on input shaft bearing	If the free play of rack shaft in radial and axial direction is out of the specified range, replace the gearbox with a new one. (Refer to "Service limit".)
5	Boot	Crack, damage or deterioration	Replace.
6	Tie-rod	(1) Looseness of ball joint (2) Bend of tie-rod	Replace.
7	Tie-rod end	Damage or deterioration on dust seal	Replace.
8	Adjusting screw spring	Deterioration	Replace.
9	Boot clip	Deterioration	Replace.
10	Sleeve	Damage	Replace.
11	Pipes	(1) Damage to flared surface (2) Damage to flare nut (3) Damage to pipe	Replace.

Steering Gearbox [RHD Model]

POWER ASSISTED SYSTEM (POWER STEERING)

2. LIMIT

Make a measurement as follows. If it exceeds the specified service limit, adjust or replace.

NOTE:

When making a measurement, vise the gearbox using ST. Never vise the gearbox by inserting aluminum plates, etc. between vise and gearbox.

ST1 926200000 STAND
ST2 34199AG000 BOSS D

Sliding resistance of rack shaft:

Limit

314 N (32 kgf, 71 lb) or less

Difference between right and left sliding resistance:

20% or less

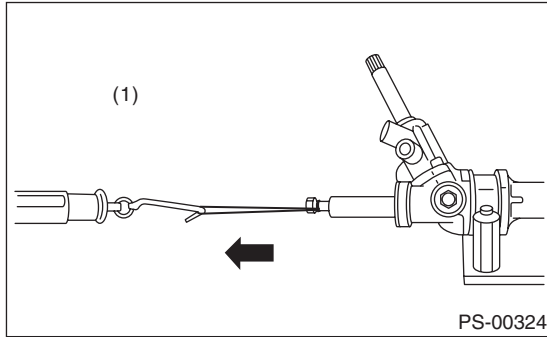

(1) Right-turn steering

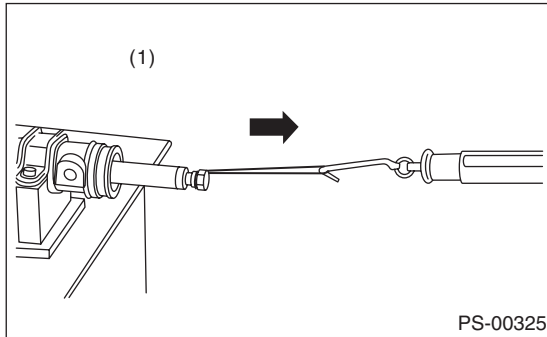

(1) Left-turn steering

3. RACK SHAFT PLAY IN RADIAL DIRECTION

Right-turn steering:

Limit

Direction ← →
0.4 mm (0.016 in) or less

Direction ⇄ ⇄
0.6 mm (0.024 in) or less

On condition

L: 5 mm (0.20 in)

P: 98 N (10 kgf, 22 lb)

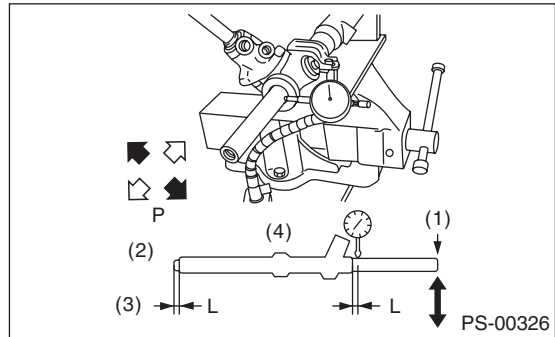

- (1) Under the step
- (2) Right-turn steering
- (3) Measure point
- (4) Right

Left-turn steering:

Limit

Direction ⇄ ⇄
0.4 mm (0.016 in) or less

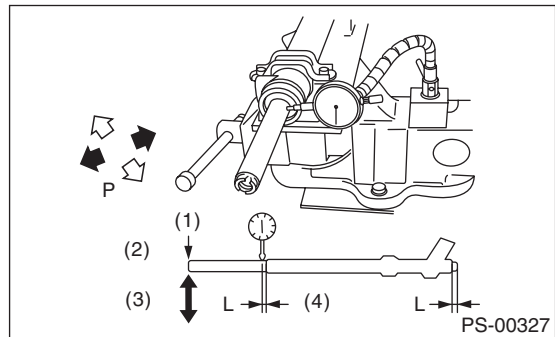

- (1) Under the step
- (2) Left-turn steering
- (3) Measure point
- (4) Left

4. INPUT SHAFT PLAY

In radial direction:

Limit

0.18 mm (0.0071 in) or less

Steering Gearbox [RHD Model]

POWER ASSISTED SYSTEM (POWER STEERING)

On condition

P: 98 N (10 kgf, 22 lb)

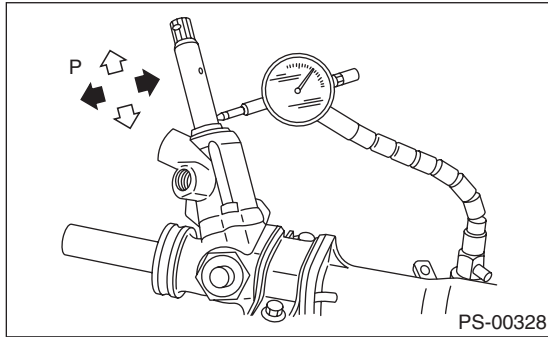

In axial direction:

Service limit

0.27 mm (0.0106 in) or less

On condition

P: 20 — 49 N (2 — 5 kgf, 4 — 11 lb)

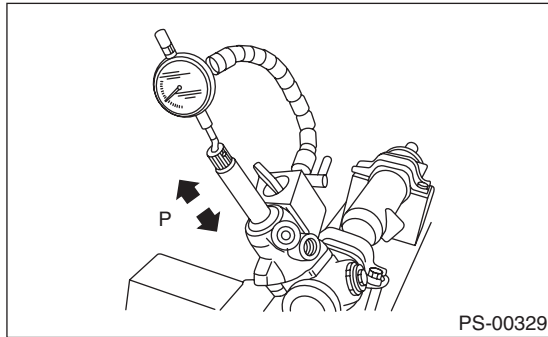

5. TURNING RESISTANCE OF GEARBOX

Using the ST, measure the gearbox turning resistance.

ST 34099PA100 SPANNER

Service limit:

Maximum allowable resistance:

13 N (1.3 kgf, 9.6 lb) or less

Difference between right and left turning resistance:

20% or less

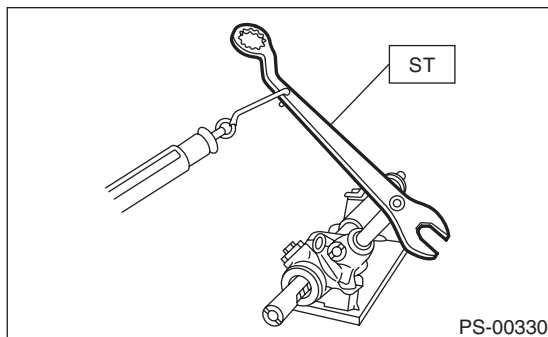

Steering Gearbox [RHD Model]

POWER ASSISTED SYSTEM (POWER STEERING)

6. OIL LEAKING

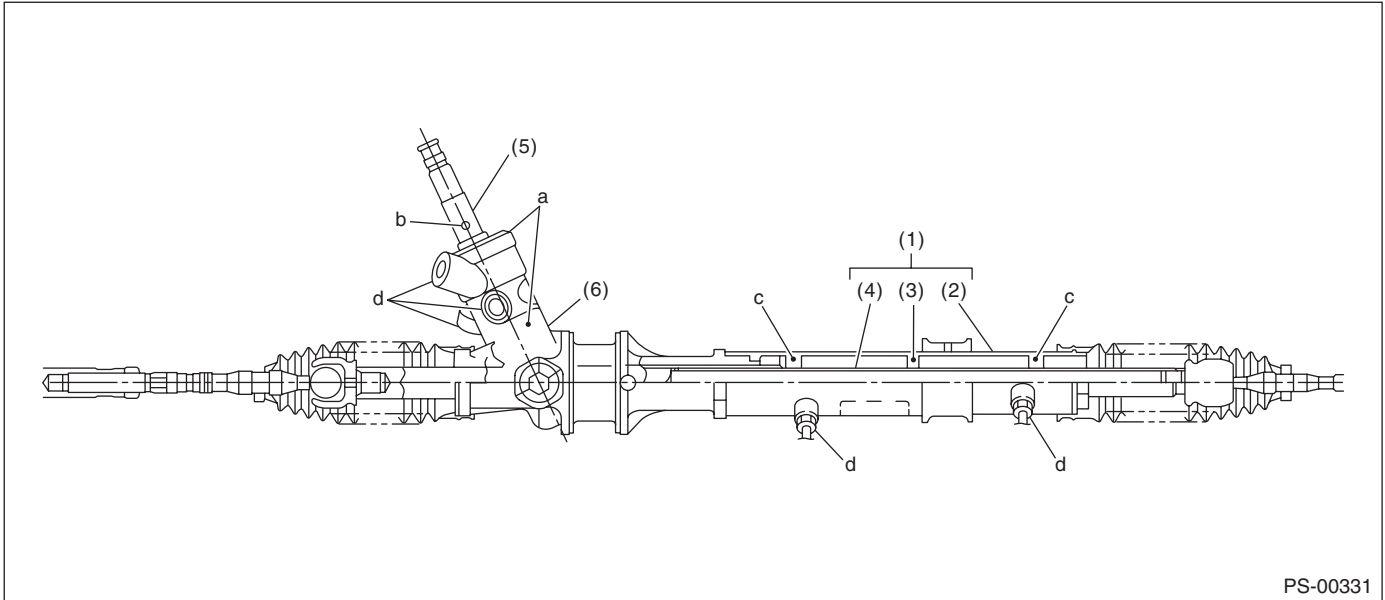

PS-00331

(1) Power cylinder

(3) Rack piston

(5) Input shaft

(2) Cylinder

(4) Rack axle

(6) Valve housing

1) Lift-up the vehicle.

2) Even if the location of leak can be easily found by observing leaking condition, it is necessary to thoroughly remove the oil from suspected portion and turn steering wheel from lock to lock about 30 to 40 times with engine running, then reinspect the suspected portion immediately after and several hours after this operation.

3) Cause and measure for oil leakage from "a"
The oil seal is damaged. Replace the valve assembly with a new one.

4) Cause and measure for oil leakage from "b"
The torsion bar O-ring is damaged. Replace the valve assembly with a new one.

5) Cause and measure for oil leakage from "c"
The oil seal is damaged. Replace the oil seal with a new one.

6) Cause and measure for oil leakage from "d"
The pipe is damaged. Replace the faulty pipe or O-ring.

F: ADJUSTMENT

1) Adjust the front toe.

<Ref. to FS-12, FRONT WHEEL TOE-IN, INSPECTION, Wheel Alignment.>

Standard of front toe:

IN 3 — OUT 3 mm (IN 0.12 — OUT 0.12 in)

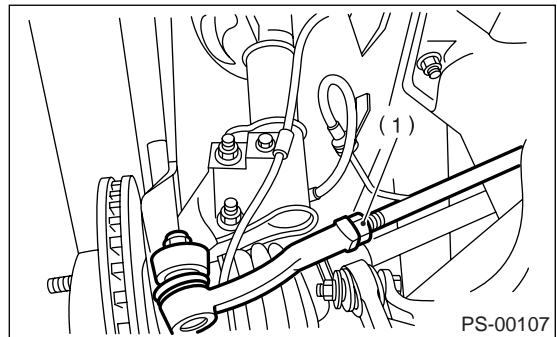

PS-00107

(1) Lock nut

2) Adjust the steering angle of wheels.

Standard of steering angle:

Model	2.0 i, 2.5 i	2.0 GT, 3.0 R	OUTBACK
Inner wheel	37.3°±1.5°	37.2°±1.5°	37.8°±1.5°
Outer wheel	33.0°±1.5°	32.9°±1.5°	33.5°±1.5°

Steering Gearbox [RHD Model]

POWER ASSISTED SYSTEM (POWER STEERING)

3) If the steering wheel spokes are not horizontal when wheels are set in the straight ahead position, or error is more than 5° on the periphery of steering wheel, correctly re-install the steering wheel.

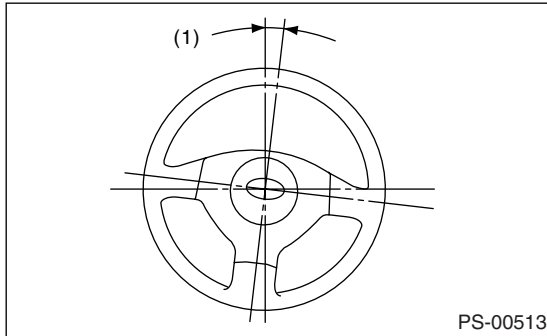

(1) Within 5°

4) If the steering wheel spokes are not horizontal with vehicle set in the straight ahead position after this adjustment, correct it by turning the right and left tie-rods in the opposite direction each other by the same angle.

Pipe Assembly [LHD Model]

POWER ASSISTED SYSTEM (POWER STEERING)

7. Pipe Assembly [LHD Model]

A: REMOVAL

- 1) Disconnect the ground cable from battery.
- 2) Lift-up the vehicle, and then remove the front crossmember support plate and jack-up plate.

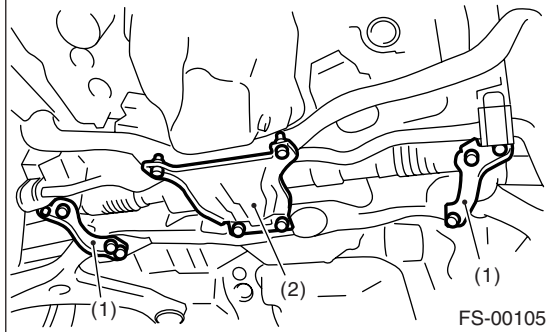

- (1) Front crossmember support plate
- (2) Jack-up plate

- 3) Remove one pipe joint at the center of gearbox, and connect the vinyl hose to the pipe and the joint. Discharge the fluid by turning steering wheel fully clockwise and counterclockwise. Discharge the fluid similarly from other pipes.

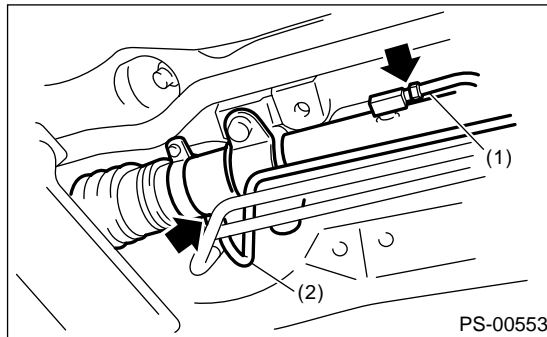

- (1) Pipe A
- (2) Pipe B

- 4) Remove the clamp E from return hose and pressure hose.

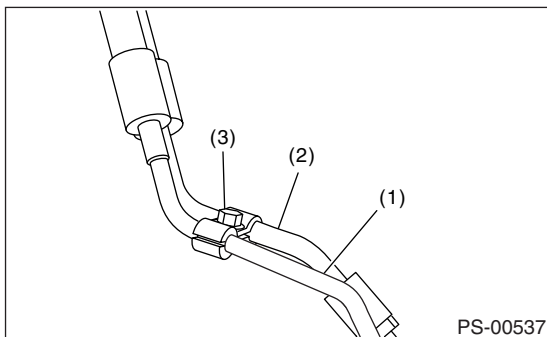

- (1) Return hose
- (2) Pressure hose
- (3) Clamp E

- 5) Disconnect the return hose and pipe D, pressure hose and pipe C.

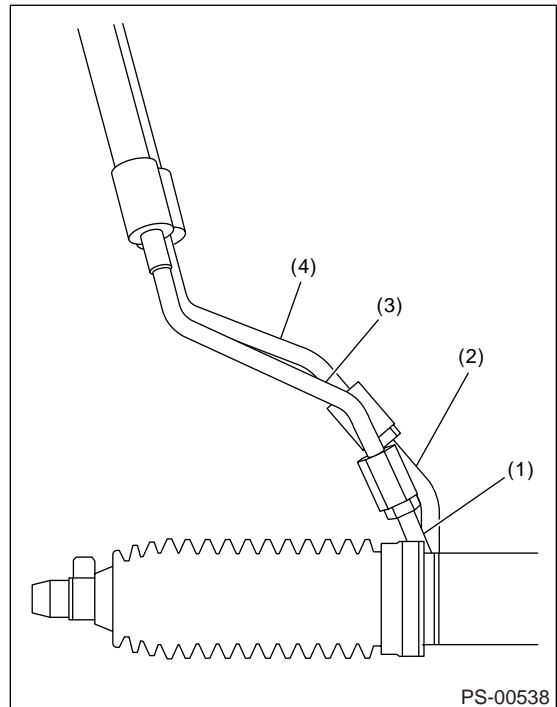

- (1) Pipe C
- (2) Pipe D
- (3) Pressure hose
- (4) Return hose

- 6) Remove the air intake duct. <Ref. to IN(H4DOTC)-9, REMOVAL, Air Intake Duct.> <Ref. to IN(H4SO 2.0)-9, REMOVAL, Air Intake Duct.>

- 7) Disconnect the suction hose and pressure hose from oil pump.

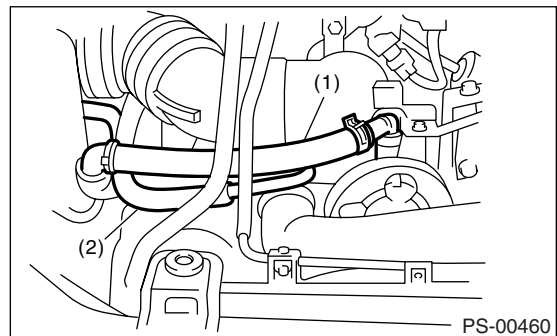

- (1) Suction hose
- (2) Pressure hose

Pipe Assembly [LHD Model]

POWER ASSISTED SYSTEM (POWER STEERING)

8) Disconnect the suction hose and return hose from reservoir tank. Remove the oil cooler from oil cooler bracket.

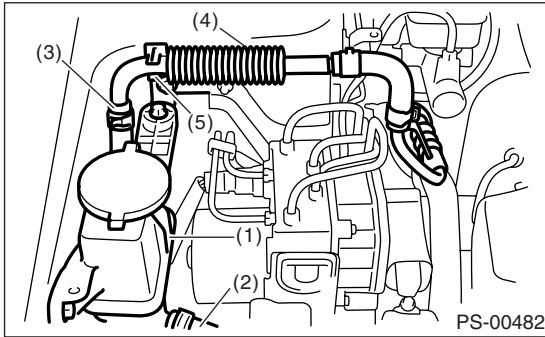

- (1) Reservoir tank
- (2) Suction hose
- (3) Return hose
- (4) Oil cooler
- (5) Oil cooler bracket

CAUTION:
Align the installation position of the resin clip with the protector edge of suction hose.

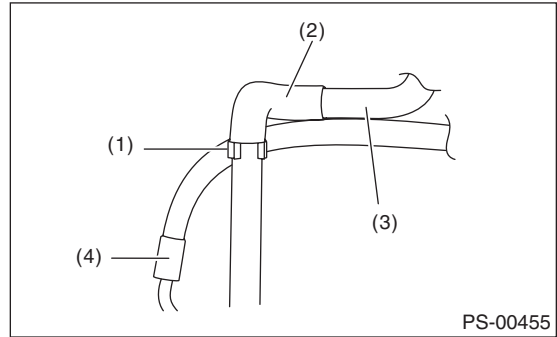

- (1) Resin clip
- (2) Protector
- (3) Suction hose
- (4) Pressure hose

9) Remove the hose bracket and take out the hose assembly from vehicle.

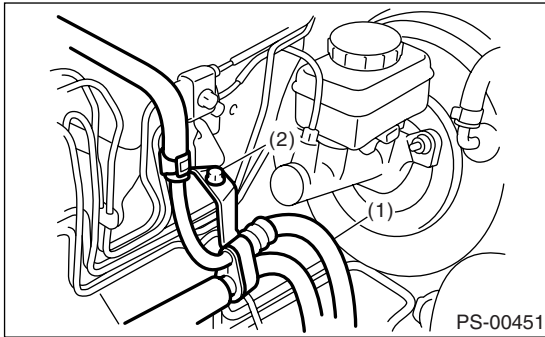

- (1) Hose ASSY
- (2) Hose bracket

3) Connect the suction hose and return hose to reservoir tank. Install the oil cooler to oil cooler bracket.

CAUTION:
Firmly insert the resin clip of return hose to the bracket.

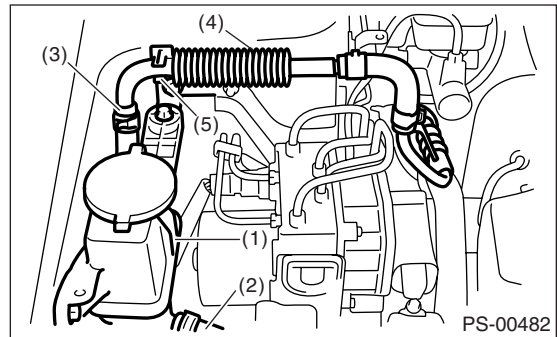

- (1) Reservoir tank
- (2) Suction hose
- (3) Return hose
- (4) Oil cooler
- (5) Oil cooler bracket

B: INSTALLATION

1) Temporarily tighten the bolt of hose bracket.

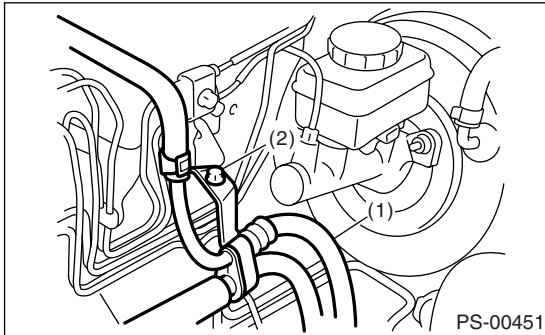

- (1) Hose ASSY
- (2) Hose bracket

4) Connect the suction hose and pressure hose to the oil pump. Tighten the eye bolt of pressure hose.

2) Install the resin clip to the pressure hose and suction hose.

Pipe Assembly [LHD Model]

POWER ASSISTED SYSTEM (POWER STEERING)

Tightening torque:

39 N·m (4.0 kgf·m, 28.9 ft·lb)

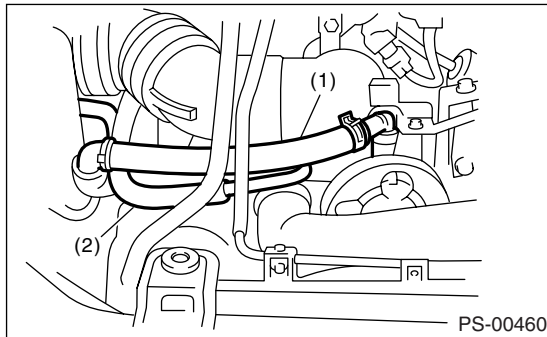

- (1) Suction hose
- (2) Pressure hose

5) Temporarily connect the pressure hose and pipe C, the return hose and D. Place the clamp E in the position shown in the figure, and tighten the bolt temporarily.

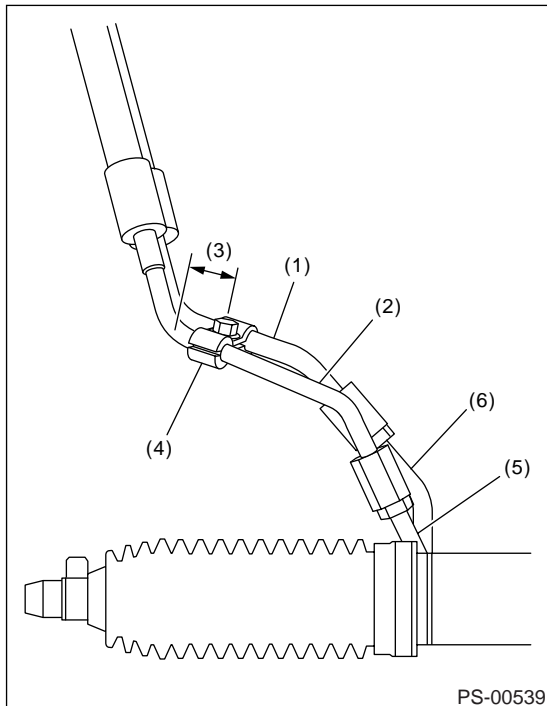

- (1) Return hose
- (2) Pressure hose
- (3) Approx. 18 mm (0.71 in)
- (4) Clamp E
- (5) Pipe C
- (6) Pipe D

NOTE:

Ensure that the letter "8" on each clamp are diagonally opposite each other as shown in the figure.

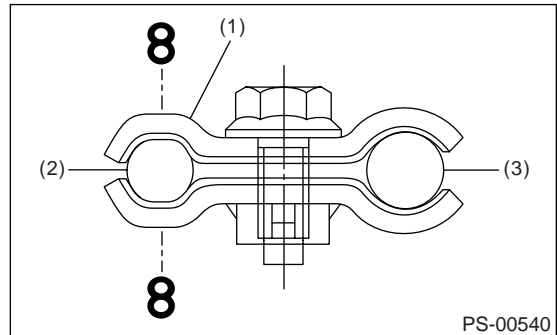

- (1) Clamp E
- (2) Pressure hose
- (3) Return hose

6) Tighten the clamp E.

Tightening torque:

7.4 N·m (0.75 kgf·m, 5.4 ft·lb)

7) Tighten the pressure hose and pipe C, the return hose and pipe D.

Tightening torque:

15 N·m (1.5 kgf·m, 10.8 ft·lb)

8) Connect the pipe A and B to the four pipe joints of gearbox.

Tightening torque:

13 N·m (1.3 kgf·m, 9.4 ft·lb)

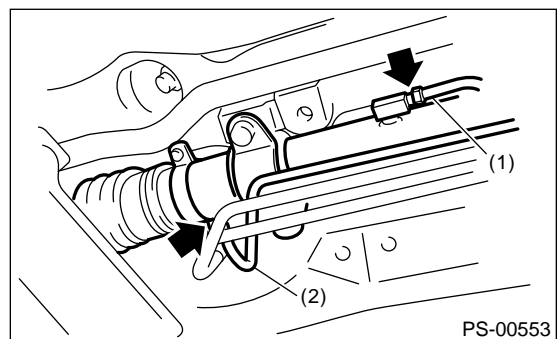

- (1) Pipe A
- (2) Pipe B

9) Install the front crossmember support plate and jack-up plate.

10) Lower the vehicle.

11) Tighten the bolts which hold the hose bracket.

Pipe Assembly [LHD Model]

POWER ASSISTED SYSTEM (POWER STEERING)

Tightening torque:

13 N·m (1.3 kgf·m, 9.4 ft·lb)

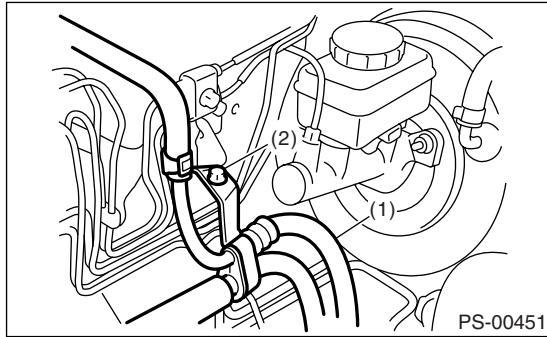

- (1) Hose ASSY
- (2) Hose bracket

12) Install the air intake duct.

<Ref. to IN(H4DOTC)-9, INSTALLATION, Air Intake Duct.> <Ref. to IN(H4SO 2.0)-9, INSTALLATION, Air Intake Duct.>

13) Connect the battery ground cable to battery.

14) Feed the specified fluid.

CAUTION:

Never start the engine before feeding the fluid; otherwise vane pump might be seized up.

15) Finally, check clearance between pipes or hoses as shown in the figure indicated in "General Diagnostic Table". <Ref. to PS-89, INSPECTION OF CLEARANCE, INSPECTION, General Diagnostic Table.>

Pipe Assembly [LHD Model]

POWER ASSISTED SYSTEM (POWER STEERING)

C: INSPECTION

Check all disassembled parts for wear, damage or other abnormalities. Repair or replace defective parts as necessary.

Parts	Maintenance Parts	Corrective action
Pipe	<ul style="list-style-type: none"> • O-ring fitting surface for damage • Nut for damage • Pipe for damage 	Replace with a new one.
Clamp	<ul style="list-style-type: none"> • Clamps for weak clamping force 	Replace with a new one.
Hose	<ul style="list-style-type: none"> • Flare surface for damage • Flare nut for damage • Outer surface for cracks • Outer surface for wear • Clip for damage • End coupling or adapter for deformation 	Replace with a new one.

CAUTION:

Although surface layer materials of rubber hoses have excellent weathering resistance, heat resistance and resistance for low temperature brittleness, they are likely to be damaged chemically by brake fluid, battery electrolyte, engine oil and automatic transmission fluid and their service lives are to be very shortened. Wipe out immediately when the hoses are adhered with the fluids.

Since resistances for heat or low temperature brittleness are gradually declining according to time accumulation of hot or cold conditions for the hoses and their service lives are shortening accordingly, it is necessary to perform careful inspection frequently when the vehicle is used in hot weather areas, cold weather areas and a driving condition in which many steering operations are required in short time.

Particularly continuous work of relief valve over 5 seconds causes to reduce service lives of the hoses, the oil pump, the fluid, etc. due to over heat.

Trouble	Possible cause	Corrective action
Pressure hose burst	Excessive holding time of relief status	Instruct customers.
	Malfunction of relief valve	Replace oil pump.
	Poor cold characteristic of fluid	Replace fluid.
Forced out return hose	Poor connection	Repair.
	Poor holding of clip	Retighten.
	Poor cold characteristic of fluid	Replace fluid.
Fluid bleeding out of hose slightly	Wrong layout, tensioned	Replace hose.
	Excessive play of engine due to deterioration of engine mounting rubber	Replace the parts if defective.
	Improper stop position of pitching stopper	Replace the parts if defective.
Crack on hose	Excessive holding time of relief status	Replace. Instruct customers.
	Excessive tightening torque of return hose clip	Replace.
	Power steering fluid, engine oil, electrolyte adhere on the hose surface	Replace. Pay attention on service work.
	Too many times use in extremely cold weather	Replace. Instruct customers.

Pipe Assembly [LHD Model]

POWER ASSISTED SYSTEM (POWER STEERING)

NOTE:

It is likely that although one judges fluid leakage, there is actually no leakage. This is because the fluid spilt during the last maintenance was not completely wiped off. Be sure to wipe off spilt fluid thoroughly after maintenance.

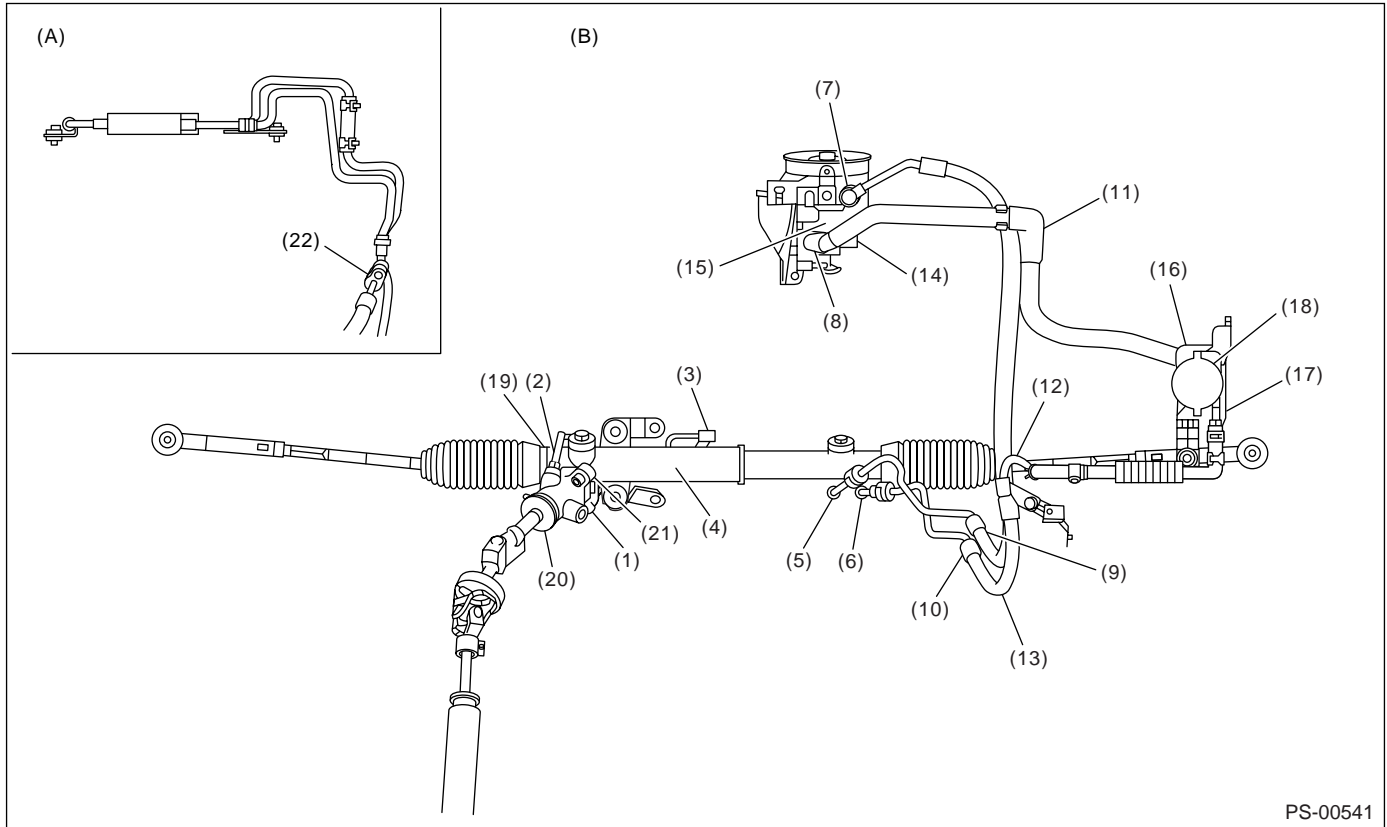

PS-00541

(A) 3.0 L model

(B) Except for 3.0 L model

Fluid leaking area	Possible cause	Corrective action
Leakage from connecting portions of pipes and hoses, numbered with (1) through (8) in figure	Insufficient tightening of flare nut, adhesion of dirt, damage to flare or flare nut or eye bolt	Loosen and retighten. Replace if ineffective.
	Poor insertion of hose or clamping	Retighten or replace the clamp.
	Damaged O-ring or gasket	Replace O-ring or gasket pipe or hose with new one, if ineffective, replace the gearbox also.
Leakage from hose (9) through (13) in figure	Crack or damage in hose	Replace with a new one.
	Crack or damage in hose hardware	Replace with a new one.
Leakage from surrounding of cast iron portion of oil pump (14) and (15) in figure	Damaged O-ring	Replace the oil pump.
	Damaged gasket	Replace the oil pump.
Leakage from oil tank (16) and (17) in figure	Crack in oil tank	Replace the oil tank.
Leakage from filler neck (18)	Damaged cap packing	Replace the cap.
	Crack in root of filler neck	Replace the oil tank.
	High fluid level	Adjust the fluid level.
Leakage from surrounding of power cylinder of gearbox (19) in figure	Damaged oil seal	Replace the oil seal.
Leakage from control valve of gearbox (20) and (21) in figure	Damaged packing or oil seal	Replace the problem parts.
	Damage in control valve	Replace the control valve.
(22) Leakage from connecting portion of cooler pipe and hose.	Insufficient tightening of connecting portion.	Loosen and retighten.

Pipe Assembly [RHD Model]

POWER ASSISTED SYSTEM (POWER STEERING)

8. Pipe Assembly [RHD Model]

A: REMOVAL

- 1) Disconnect the ground cable from battery.
- 2) Lift-up the vehicle, and then remove the front crossmember support plate and jack-up plate.

- Large type

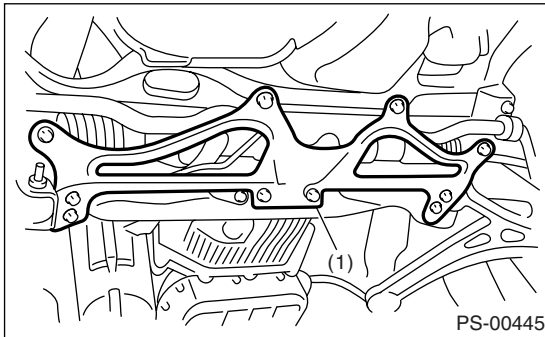

(1) Front crossmember support plate

- Small type

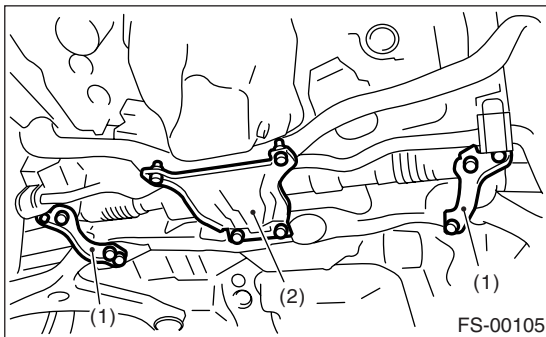

(1) Front crossmember support plate
(2) Jack-up plate

- 3) Remove one pipe joint at the center of gearbox, and connect the vinyl hose to the pipe and the joint. Discharge the fluid by turning steering wheel fully clockwise and counterclockwise. Discharge the fluid similarly from other pipes.

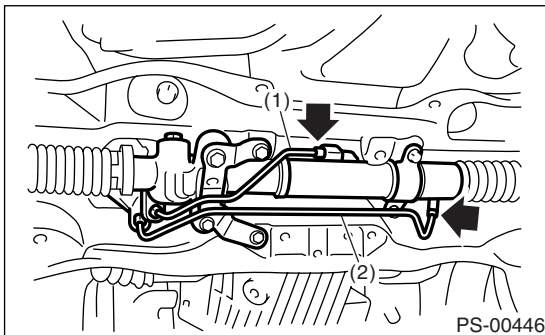

(1) Pipe A
(2) Pipe B

- 4) Remove the clamp E from the return hose and pressure hose.

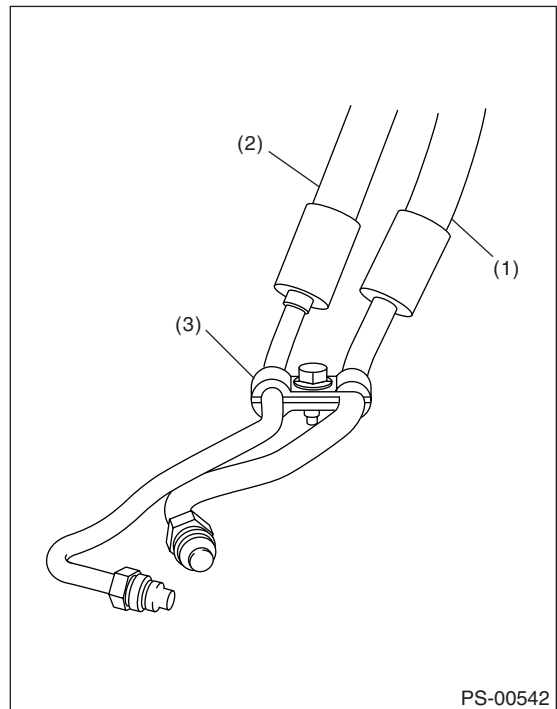

(1) Return hose
(2) Pressure hose
(3) Clamp E

- 5) Disconnect the return hose and pressure hose from gearbox.

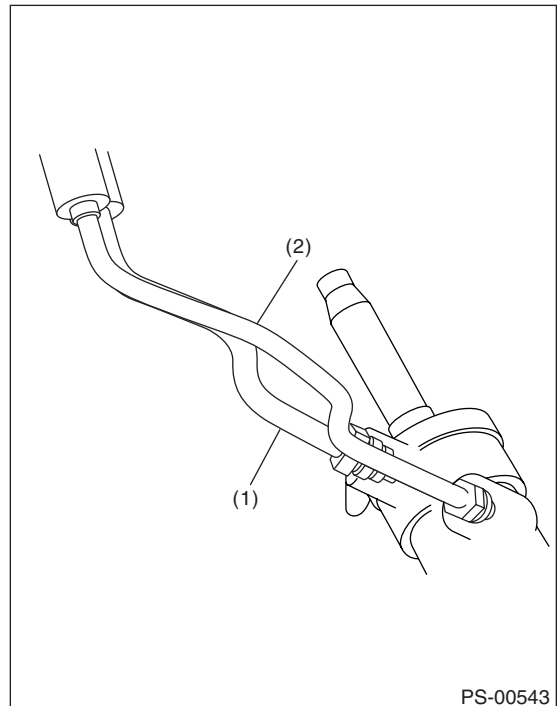

(1) Return hose
(2) Pressure hose

Pipe Assembly [RHD Model]

POWER ASSISTED SYSTEM (POWER STEERING)

6) Remove the air intake duct. <Ref. to IN(H4DOTC)-9, REMOVAL, Air Intake Duct.>
<Ref. to IN(H4SO 2.0)-9, REMOVAL, Air Intake Duct.>

7) Disconnect the suction hose and pressure hose from the oil pump.

- Non-turbo model

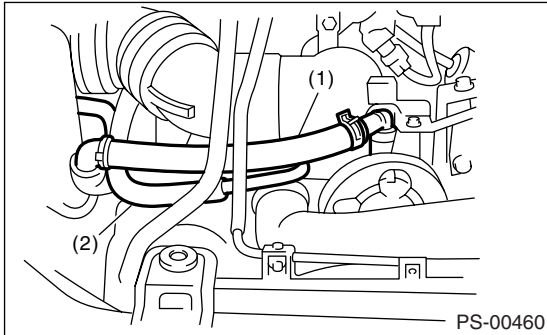

- Turbo model

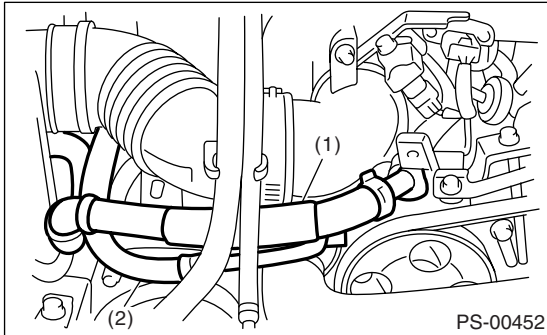

- (1) Suction hose
- (2) Pressure hose

8) Disconnect the suction hose and return hose from reservoir tank. Remove the oil cooler from oil cooler bracket.

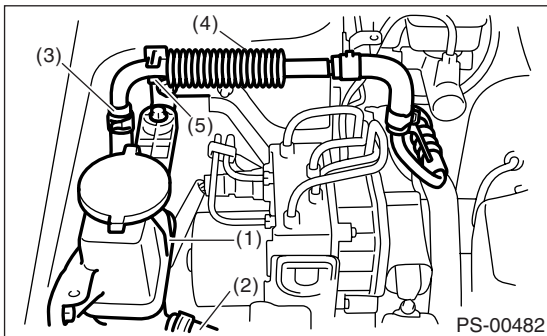

- (1) Reservoir tank
- (2) Suction hose
- (3) Return hose
- (4) Oil cooler
- (5) Oil cooler bracket

9) Remove the hose bracket and take out the hose assembly from vehicle.

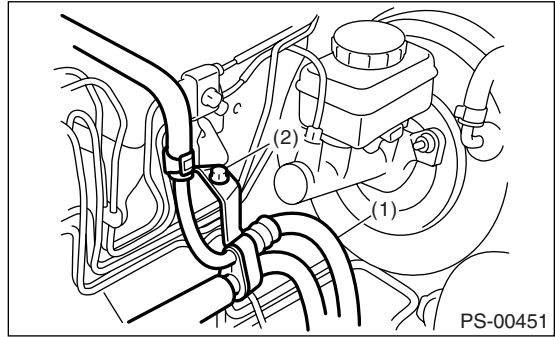

- (1) Hose ASSY
- (2) Hose bracket

B: INSTALLATION

1) Temporarily tighten the bolt of hose bracket.

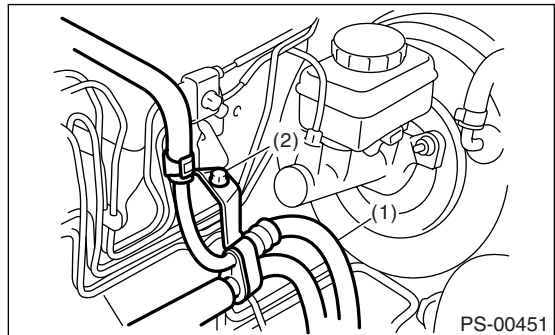

- (1) Hose ASSY
- (2) Hose bracket

2) Install the resin clip to the pressure hose and suction hose.

CAUTION:

Align the installation position of the resin clip with the protector edge of suction hose.

- Non-turbo model

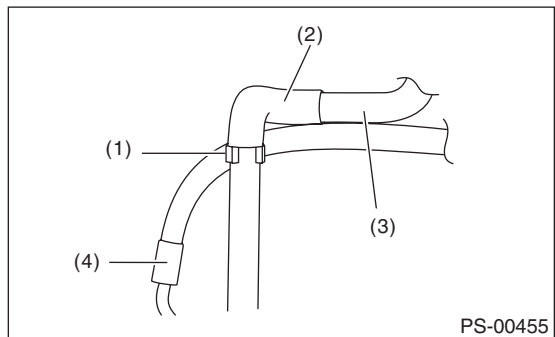

- (1) Resin clip
- (2) Protector
- (3) Suction hose
- (4) Pressure hose

Pipe Assembly [RHD Model]

POWER ASSISTED SYSTEM (POWER STEERING)

- Turbo model

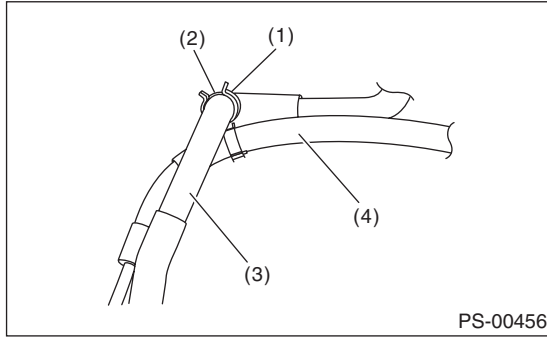

- (1) Resin clip
- (2) Protector
- (3) Suction hose
- (4) Pressure hose

3) Connect the suction hose and return hose to reservoir tank. Install the oil cooler to oil cooler bracket.

CAUTION:
Firmly insert the resin clip of return hose to the bracket.

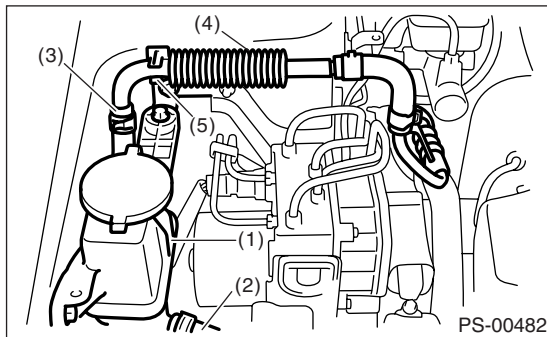

- (1) Reservoir tank
- (2) Suction hose
- (3) Return hose
- (4) Oil cooler
- (5) Oil cooler bracket

4) Connect the suction hose and pressure hose to the oil pump. Tighten the eye bolt of pressure hose.

Tightening torque:

39 N·m (4.0 kgf·m, 28.9 ft·lb)

- Non-turbo model

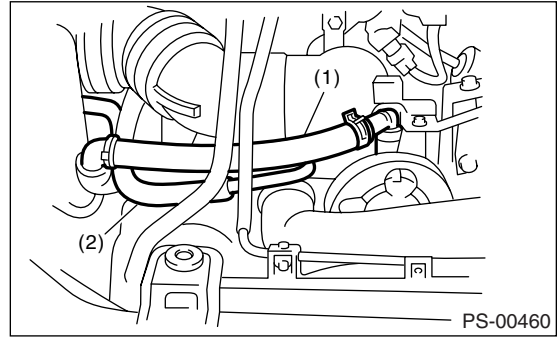

- (1) Suction hose
- (2) Pressure hose

- Turbo model

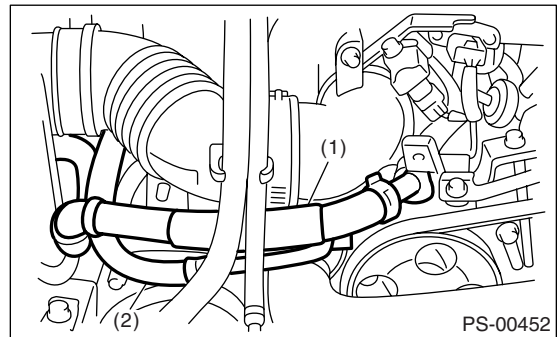

- (1) Suction hose
- (2) Pressure hose

Pipe Assembly [RHD Model]

POWER ASSISTED SYSTEM (POWER STEERING)

5) Temporarily connect the return hose and pressure hose to gearbox. Place the clamp E in the position shown in the figure, and tighten the bolt temporarily.

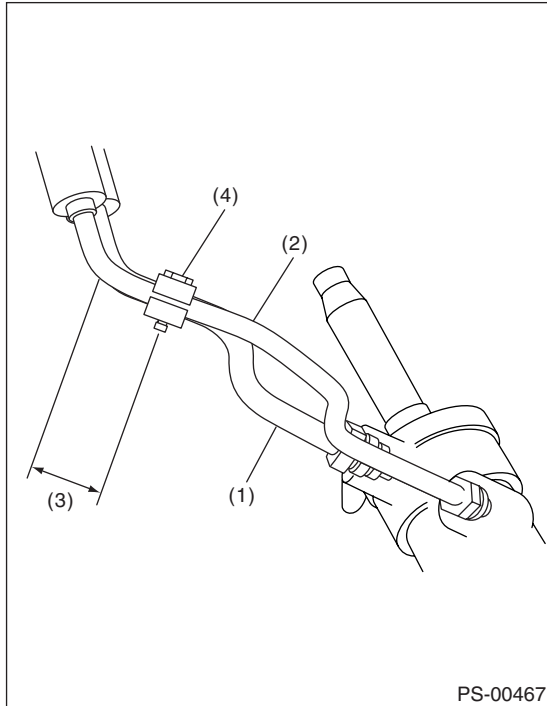

- (1) Return hose
- (2) Pressure hose
- (3) Approx. 27 mm (1.06 in)
- (4) Clamp E

NOTE:

Ensure that the letter "8" on each clamp are diagonally opposite each other as shown in the figure.

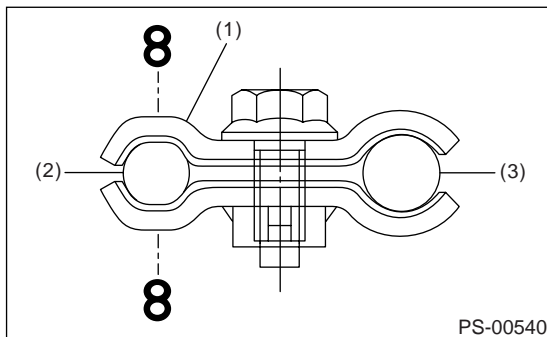

- (1) Clamp E
- (2) Pipe C
- (3) Return hose

6) Tighten the clamp E.

Tightening torque:

7.4 N·m (0.75 kgf-m, 5.4 ft-lb)

7) Tighten the joint nut.

Tightening torque:

15 N·m (1.5 kgf-m, 10.8 ft-lb)

8) Connect the pipe A and B to the four pipe joints of gearbox.

Tightening torque:

13 N·m (1.3 kgf-m, 9.4 ft-lb)

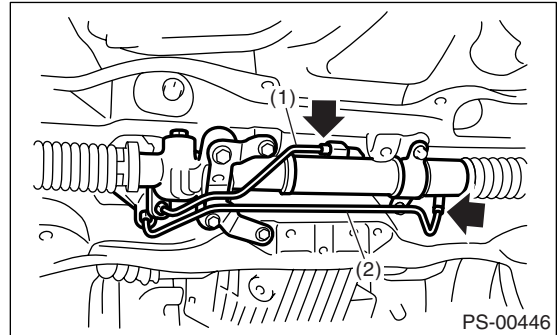

- (1) Pipe A
- (2) Pipe B

9) Install the front crossmember support plate and jack-up plate.

10) Lower the vehicle.

11) Tighten the bolts which hold the hose bracket.

Tightening torque:

13 N·m (1.3 kgf-m, 9.4 ft-lb)

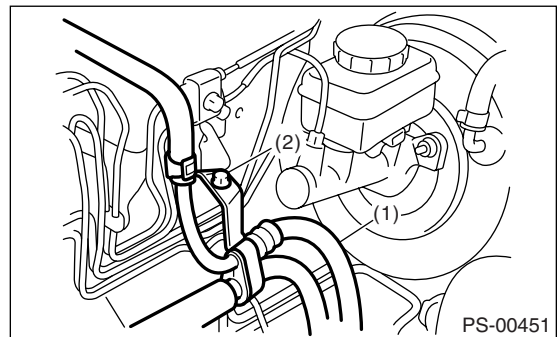

- (1) Hose ASSY
- (2) Hose bracket

12) Install the air intake duct.

<Ref. to IN(H4DOTC)-9, INSTALLATION, Air Intake Duct.> <Ref. to IN(H4SO 2.0)-9, INSTALLATION, Air Intake Duct.>

13) Connect the battery ground cable to battery.

14) Feed the specified fluid.

CAUTION:

Never start the engine before feeding the fluid; otherwise vane pump might be seized up.

Pipe Assembly [RHD Model]

POWER ASSISTED SYSTEM (POWER STEERING)

15) Finally, check clearance between pipes or hoses as shown in the figure indicated in "General Diagnostic Table". <Ref. to PS-89, INSPECTION OF CLEARANCE, INSPECTION, General Diagnostic Table.>

C: INSPECTION

Check all disassembled parts for wear, damage or other abnormalities. Repair or replace defective parts as necessary.

Parts	Maintenance Parts	Corrective action
Pipe	<ul style="list-style-type: none"> O-ring fitting surface for damage Nut for damage Pipe for damage 	Replace with a new one.
Clamp	<ul style="list-style-type: none"> Clamps for weak clamping force 	Replace with a new one.
Hose	<ul style="list-style-type: none"> Flare surface for damage Flare nut for damage Outer surface for cracks Outer surface for wear Clip for damage End coupling or adapter for deformation 	Replace with a new one.

CAUTION:

Although surface layer materials of rubber hoses have excellent weathering resistance, heat resistance and resistance for low temperature brittleness, they are likely to be damaged chemically by brake fluid, battery electrolyte, engine oil and automatic transmission fluid and their service lives are to be very shortened. Wipe out immediately when the hoses are adhered with the fluids.

Since resistances for heat or low temperature brittleness are gradually declining according to time accumulation of hot or cold conditions for the hoses and their service lives are shortening accordingly, it is necessary to perform careful inspection frequently when the vehicle is used in hot weather areas, cold weather areas and a driving condition in which many steering operations are required in short time.

Particularly continuous work of relief valve over 5 seconds causes to reduce service lives of the hoses, the oil pump, the fluid, etc. due to over heat.

Trouble	Possible cause	Corrective action
Pressure hose burst	Excessive holding time of relief status	Instruct customers.
	Malfunction of relief valve	Replace oil pump.
	Poor cold characteristic of fluid	Replace fluid.
Forced out return hose	Poor connection	Repair.
	Poor holding of clip	Retighten.
	Poor cold characteristic of fluid	Replace fluid.
Fluid bleeding out of hose slightly	Wrong layout, tensioned	Replace hose.
	Excessive play of engine due to deterioration of engine mounting rubber	Replace the parts if defective.
	Improper stop position of pitching stopper	Replace the parts if defective.
Crack on hose	Excessive holding time of relief status	Replace. Instruct customers.
	Excessive tightening torque of return hose clip	Replace.
	Power steering fluid, engine oil, electrolyte adhere on the hose surface	Replace. Pay attention on service work.
	Too many times use in extremely cold weather	Replace. Instruct customers.

Pipe Assembly [RHD Model]

POWER ASSISTED SYSTEM (POWER STEERING)

NOTE:

It is likely that although one judges fluid leakage, there is actually no leakage. This is because the fluid spilt during the last maintenance was not completely wiped off. Be sure to wipe off spilt fluid thoroughly after maintenance.

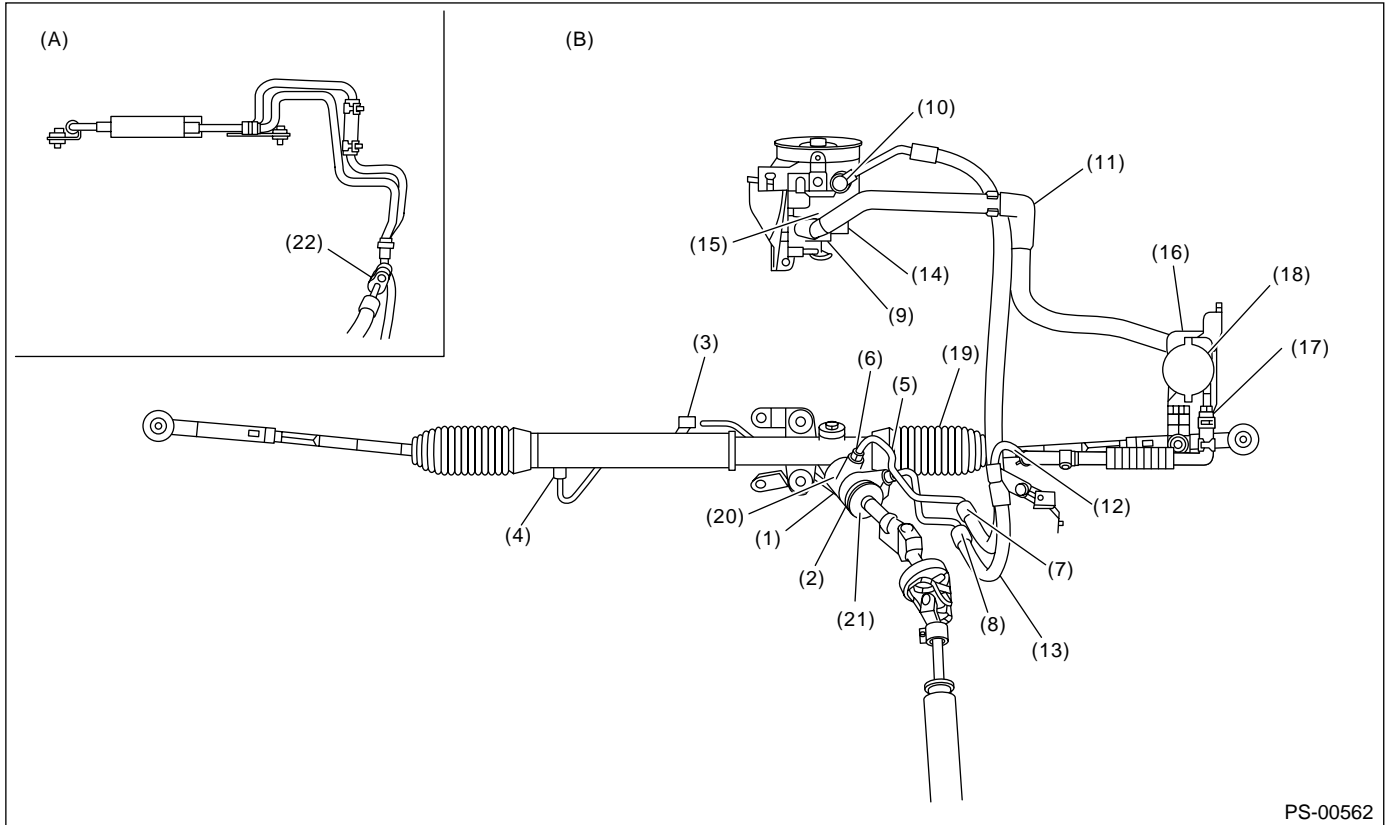

PS-00562

(A) 3.0 L model

(B) Except for 3.0 L model

Fluid leaking area	Possible cause	Corrective action
Leakage from connecting portions of pipes and hoses, numbered with (1) through (10) in figure	Insufficient tightening of flare nut, adhesion of dirt, damage to flare or flare nut or eye bolt	Loosen and retighten. Replace if ineffective.
	Poor insertion of hose or clamping	Retighten or replace the clamp.
	Damaged O-ring or gasket	Replace O-ring or gasket pipe or hose with new one, if ineffective, replace the gearbox also.
Leakage from hose (11), (12) and (13) in figure	Crack or damage in hose	Replace with a new one.
	Crack or damage in hose hardware	Replace with a new one.
Leakage from surrounding of cast iron portion of oil pump (14) and (15) in figure	Damaged O-ring	Replace the oil pump.
	Damaged gasket	Replace the oil pump.
Leakage from oil tank (16) and (17) in figure	Crack in oil tank	Replace the oil tank.
Leakage from filler neck (18)	Damaged cap packing	Replace the cap.
	Crack in root of filler neck	Replace the oil tank.
	High fluid level	Adjust the fluid level.
Leakage from surrounding of power cylinder of gearbox (19) in figure	Damaged oil seal	Replace the oil seal.
Leakage from control valve of gearbox (20) and (21) in figure	Damaged packing or oil seal	Replace the problem parts.
	Damage in control valve	Replace the control valve.
(22) Leakage from connecting portion of cooler pipe and hose.	Insufficient tightening of connecting portion.	Loosen and retighten.

Oil Pump

POWER ASSISTED SYSTEM (POWER STEERING)

9. Oil Pump

A: REMOVAL

- 1) Disconnect the ground cable from battery.
- 2) Remove the air intake duct. <Ref. to IN(H4DOTC)-9, REMOVAL, Air Intake Duct.> <Ref. to IN(H4SO 2.0)-9, REMOVAL, Air Intake Duct.>
- 3) Remove the pulley belt cover.
- 4) Loosen the belt tension securing bolt and generator securing bolt, and then remove the power steering pump V-belt.

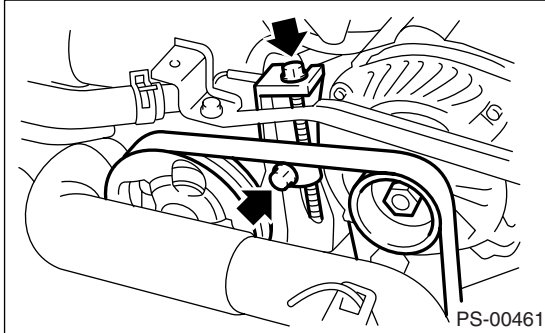

- 5) Disconnect the connector from power steering pump switch.
- 6) Disconnect the pressure hose and suction hose from oil pump.

CAUTION:

- Do not allow fluid to come into contact with pulley belt.
- To prevent foreign matter from entering the hose and pipe, cover the open ends with a clean cloth.
- Non-turbo model

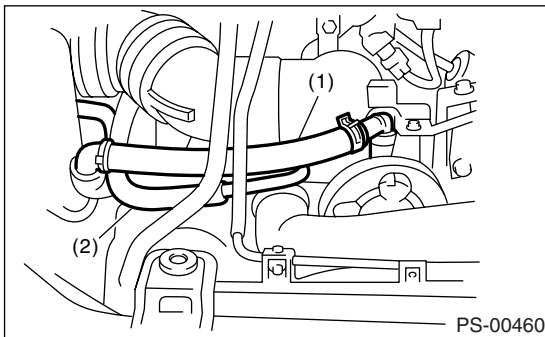

- (1) Suction hose
- (2) Pressure hose

- Turbo model

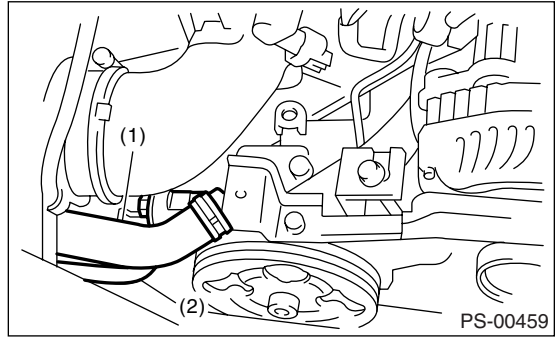

- (1) Suction hose
- (2) Pressure hose

- 7) Remove the bolts which hold the power steering pump bracket.

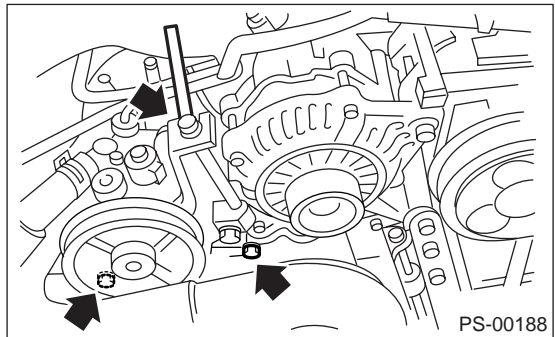

- 8) Place the oil pump bracket in a vise, and remove the two bolts from the front side of oil pump.

CAUTION:

- When securing the oil pump bracket in a vise, hold the oil pump bracket with the least possible force between two wood pieces.

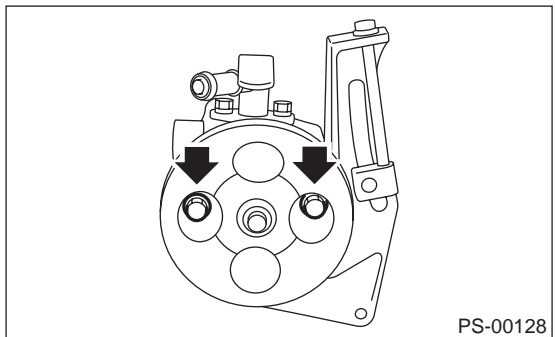

- 9) Remove the bolt from the rear side of oil pump.

Oil Pump

POWER ASSISTED SYSTEM (POWER STEERING)

10) Disassemble the oil pump and bracket by inserting a flat tip screwdriver as shown in the figure.

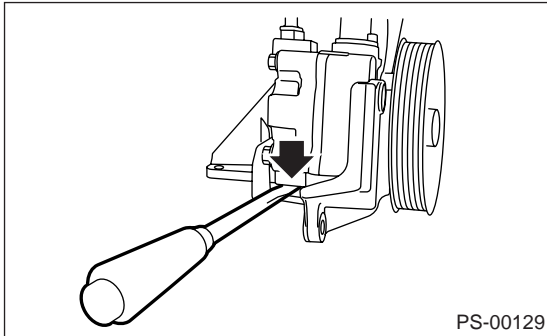

Tightening torque:

37.3 N·m (3.8 kgf-m, 27.5 ft-lb)

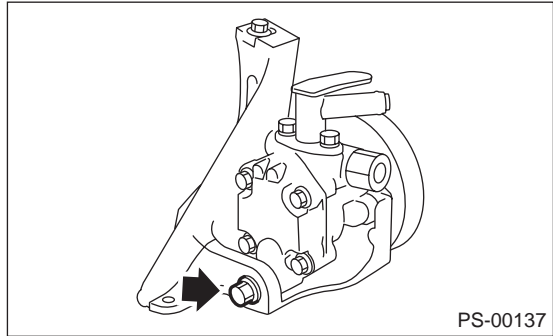

B: INSTALLATION

1) Install the oil pump to bracket.

(1) Place the oil pump bracket in a vise. Tighten the bushing using a 12.7 mm (1/2") type 14- and 21-mm box wrench until it contact with oil pump mounting surface.

CAUTION:

When securing the oil pump bracket on a vice, hold the oil pump bracket with the least possible force between two wood pieces.

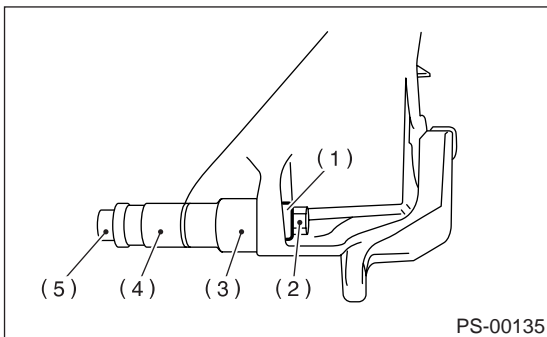

- (1) Bushing
- (2) Nut
- (3) 21 mm
- (4) 14 mm
- (5) Bolt

(2) Tighten the bolt which holds the oil pump to bracket.

Tightening torque:

15.7 N·m (1.6 kgf-m, 11.6 ft-lb)

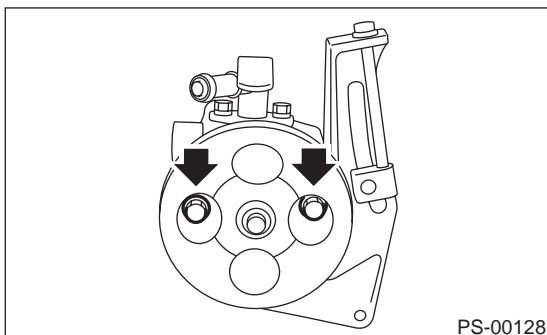

2) Tighten the bolts which hold the power steering pump bracket.

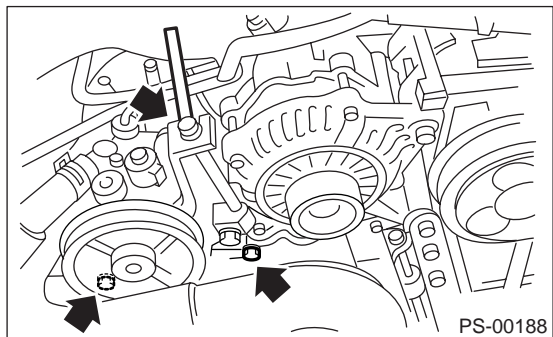

3) Interconnect the pressure hose and suction hose.

Tightening torque:

Eye bolt

39 N·m (4.0 kgf-m, 28.9 ft-lb)

CAUTION:

If a hose is twisted at this step, take care the hose may come into contact with some other parts.

- Non-turbo model

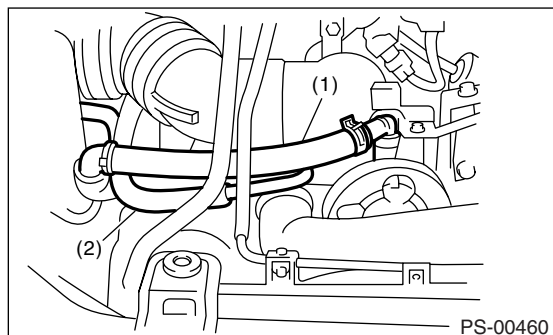

- (1) Suction hose
- (2) Pressure hose

Oil Pump

POWER ASSISTED SYSTEM (POWER STEERING)

- Turbo model

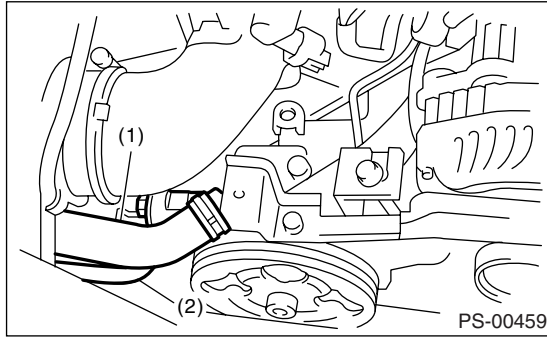

- (1) Suction hose
- (2) Pressure hose

- 4) Connect the connector to power steering pump switch.
- 5) Install the V-belts to oil pump.
- 6) Check the tension of V-belt.
<Ref. to ME(H4SO 2.0)-39, INSPECTION, V-belt.>
- 7) Tighten the belt tension bolt.

Tightening torque:

25 N·m (2.5 kgf-m, 18.1 ft-lb)

- 8) Install the pulley belt cover.
- 9) Install the air intake duct.
<Ref. to IN(H4DOTC)-9, INSTALLATION, Air Intake Duct.> <Ref. to IN(H4SO 2.0)-9, INSTALLATION, Air Intake Duct.>
- 10) Connect the battery ground cable to battery.
- 11) Feed the specified power steering fluid. <Ref. to PS-84, Power Steering Fluid.>

CAUTION:

Never start the engine before feeding the fluid; otherwise vane pump might be seized up.

Oil Pump

POWER ASSISTED SYSTEM (POWER STEERING)

C: INSPECTION

1. BASIC INSPECTION

Perform the following inspection procedures and replace defective parts.

No.	Parts	INSPECTION	Corrective action
1	Oil pump (Exterior)	(1) Crack, damage or oil leakage	Replace the oil pump with a new one.
		(2) Play of pulley shaft	Measure the radial play and axial play. If any of these exceeds the service limit, replace the oil pump with a new one.
2	Pulley	(1) Damage	Replace with a new one.
		(2) Bend	Measure the V ditch deflection. If it exceeds the service limit, replace the pulley with a new one.
3	Oil pump (Interior)	(1) Defect or burning of vane pump	Check the resistance to the rotation of pulley. If it exceeds the service limit, replace the oil pump with a new one.
		(2) Bend in the shaft or damage to bearing	Oil pump emits a noise that is markedly different in tone and loudness from a sound of a new oil pump when turning its pulley which is put around with a string, replace the oil pump with a new one.
4	O-ring	Crack or deterioration	Replace with a new one.
5	Bracket	Crack	Replace with a new one.

2. SERVICE LIMIT

Make a measurement as follows. If it exceeds the service limit, replace with a new one.

CAUTION:

- When securing the oil pump on a vice, hold the oil pump with the least possible force between two wood pieces.
- Do not set outside of flow control valve or pulley on a vice; otherwise outside or pulley might be deformed. Select properly sized wood pieces.

1) Play of the pulley shaft

Condition:

P: When applying the force of 9.8 N (1.0 kgf, 2.2 lb)

Service limit:

Radial play (Direction \longleftrightarrow)
0.4 mm (0.016 in) or less

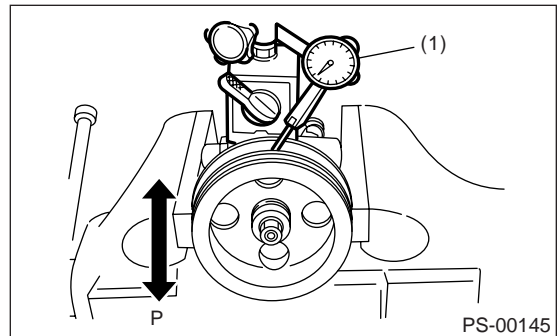

(1) Dial gauge

Axial play (Direction \longleftrightarrow)
0.9 mm (0.035 in) or less

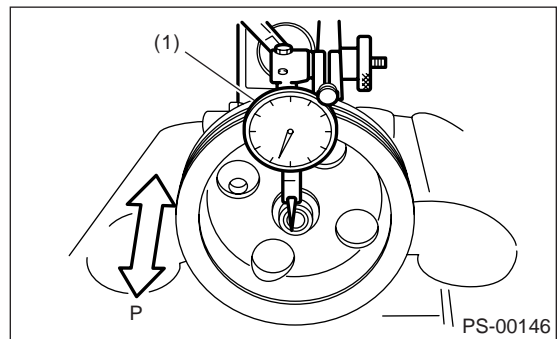

(1) Dial gauge

Oil Pump

POWER ASSISTED SYSTEM (POWER STEERING)

2) Ditch deflection of pulley

Service limit:

1.0 mm (0.039 in) or less

NOTE:

Read the value for one surface of V ditch, and then the value for another off the dial.

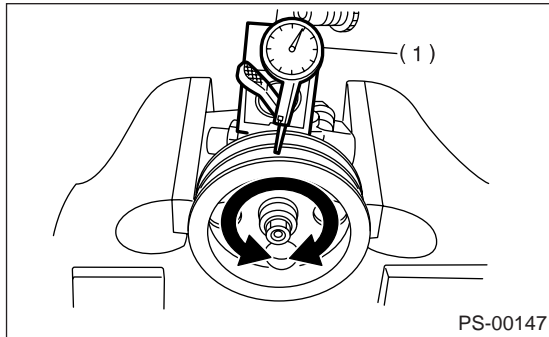

(1) Dial gauge

3) Resistance to rotation of pulley

Service limit:

Maximum load: 9.22 N (0.94 kgf, 2.07 lb) or less

NOTE:

- A rather higher value may be indicated when pulley starts turning.
- Measure the load during rotation to make a judgment.

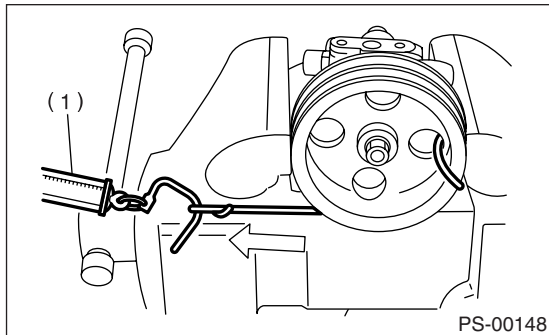

(1) Spring balance

3. HYDRAULIC PRESSURE

NOTE:

- Be sure to complete all items aforementioned in "INSPECTION", prior to measuring hydraulic pressure. Otherwise, pressure cannot be measured correctly. <Ref. to PS-85, INSPECTION, General Diagnostic Table.>
- Do not leave the valve of pressure gauge closed or hold the steering wheel at stop end for 5 seconds or more in any case, as the oil pump may be damaged due to long keep of these conditions.

- Put cloth at a place where fluid drops before pressure gauge is installed. Wipe off spilt fluid thoroughly after the measurement.

1) Regular pressure measurement

(1) Connect ST1, ST2 and ST3.

ST1 925711000 PRESSURE GAUGE

ST2 34099AC020 ADAPTER HOSE B

ST3 34099AC010 ADAPTER HOSE A

(2) Remove the air intake duct.

(3) Disconnect the pipe C from pump.

(4) Using the gasket (Part No. 34621AC021) and bolt (Part No. 34620AC010), install the ST2 to pump instead of pressure hose.

- Non-turbo model

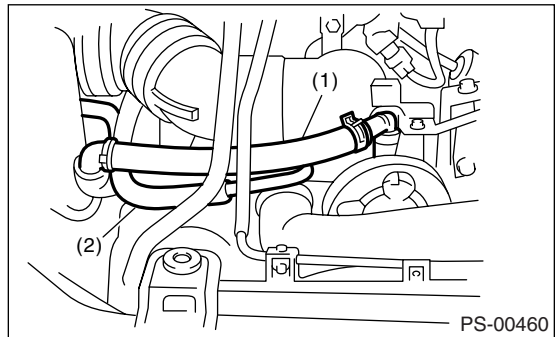

(1) Suction hose

(2) Pressure hose

- Turbo model

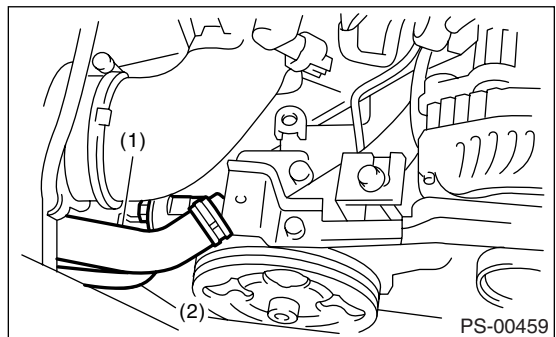

(1) Suction hose

(2) Pressure hose

(5) Install the ST3 to the end of pressure hose which is removed from pump.

(6) Replenish the power steering fluid up to specified level.

(7) Open the valve, and start the engine.

Oil Pump

POWER ASSISTED SYSTEM (POWER STEERING)

(8) Measure the regular pressure.

ST1 925711000 PRESSURE GAUGE

ST2 34099AC020 ADAPTER HOSE B

ST3 34099AC010 ADAPTER HOSE A

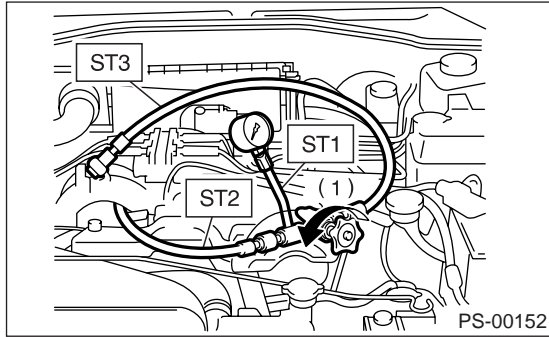

(1) Valve

Service limit:

981 kPa (10 kg/cm², 142 psi) or less

(9) If it is not within the specified value, replace the troubled part caused by following symptoms. (Pipe or hose clogged, leaks from fluid line, and mixture of foreign matters in fluid line)

2) Measure the relief pressure.

(1) Using the STs, measure the relief pressure.

(2) Close the valve.

(3) Measure the relief pressure.

ST1 925711000 PRESSURE GAUGE

ST2 34099AC020 ADAPTER HOSE B

ST3 34099AC010 ADAPTER HOSE A

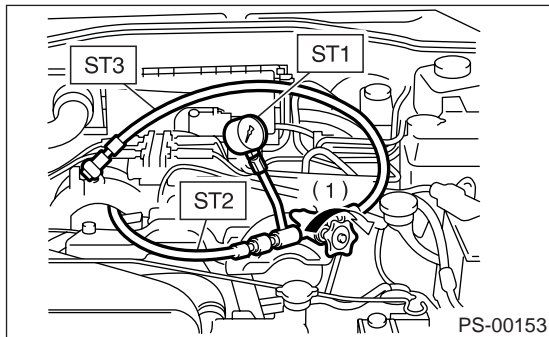

(1) Valve

Service limit:

Non-turbo model (Except for 3.0 R model):

6,767 — 7,453 kPa

(69 — 76 kg/cm², 981 — 1,081 psi)

Turbo model:

7,350 — 8,036 kPa

(75 — 82 kg/cm², 1,067 — 1,165 psi)

3.0 R model:

8,300 — 9,000 kPa

(85 — 92 kg/cm², 1,204 — 1,305 psi)

(4) If it is not within the specified value, replace the oil pump.

3) Measure working pressure.

(1) Using the STs, measure the working pressure.

(2) Open the valve.

(3) Measure the working pressure of control valve by turning steering wheel from stop to stop.

ST1 925711000 PRESSURE GAUGE

ST2 34099AC020 ADAPTER HOSE B

ST3 34099AC010 ADAPTER HOSE A

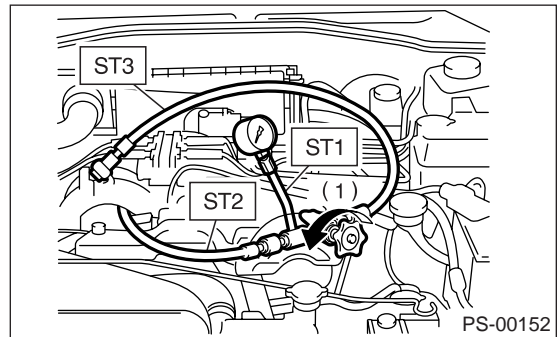

(1) Valve

Service limit:

7,650 — 8,330 kPa (78 — 85 kg/cm², 1,110 — 1,208 psi)

(4) If it is not within the specified value, measure the steering effort. <Ref. to PS-88, MEASUREMENT OF STEERING EFFORT, INSPECTION, General Diagnostic Table.> If it is not within specified value, replace the control valve itself or control valve and pinion as a single unit with new ones.

Reservoir Tank

POWER ASSISTED SYSTEM (POWER STEERING)

10. Reservoir Tank

A: REMOVAL

- 1) Drain fluid from the reservoir tank.
- 2) Disconnect the hose from reservoir tank.

CAUTION:

To prevent foreign matter from entering the hose and pipe, cover the open ends of them with a clean cloth.

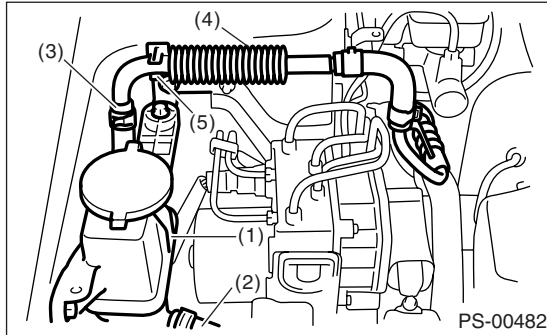

- (1) Reservoir tank
- (2) Suction hose
- (3) Return hose
- (4) Oil cooler
- (5) Oil cooler bracket

- 3) Remove the reservoir tank from body.

B: INSTALLATION

- 1) Install the reservoir tank to body.

Tightening torque:

13 N·m (1.3 kgf·m, 9.4 ft·lb)

- 2) Connect the hose to reservoir tank.

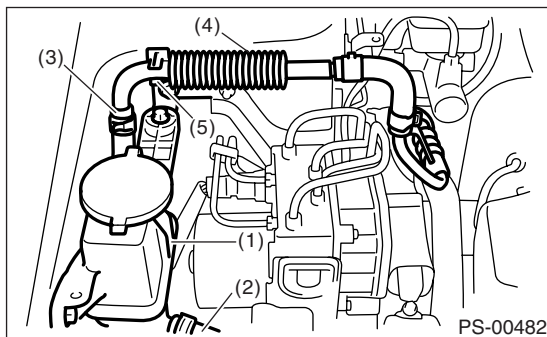

- (1) Reservoir tank
- (2) Suction hose
- (3) Return hose
- (4) Oil cooler
- (5) Oil cooler bracket

- 3) Feed the power steering fluid to specified level.
<Ref. to PS-84, Power Steering Fluid.>

Power Steering Fluid

POWER ASSISTED SYSTEM (POWER STEERING)

11. Power Steering Fluid

A: SPECIFICATION

Recommended power steering fluid	Manufacturer
ATF DEXRON III or equivalent	B.P.
	CALTEX
	CASTROL
	MOBIL
	SHELL
	TAXACO

B: INSPECTION

1) Check the power steering fluid for deterioration and contamination. If the fluid is highly deteriorated or contaminated, drain it and refill with new fluid.

2) Check the joints and units for oil leakage. If any oil leaks are found, repair or replace the applicable part.

3) Inspect the fluid level on flat and level surface with engine "OFF" by indicator of reservoir tank.

If the level is at "MIN." point or below, add fluid to keep the level in the specified range of the indicator. If at "MAX." point or above, drain fluid by using a syringe or the like.

(1) Check at power steering fluid temperature 20°C (68°F); read the fluid level on the "COLD" side.

(2) Check at power steering fluid temperature 80°C (176°F); read the fluid level on the "HOT" side.

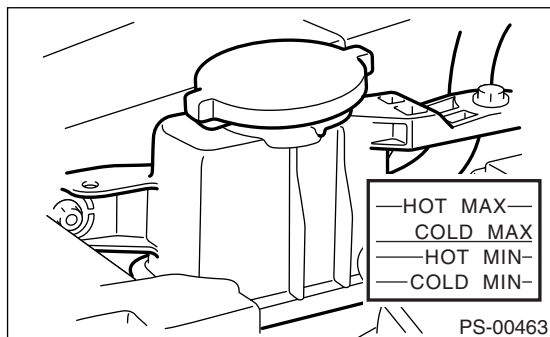

C: REPLACEMENT

1) Lift-up the vehicle.

2) Remove the crossmember support.

3) Remove the pipe joint in the center of gearbox, and connect the vinyl hose to the pipe and joint. Wipe fluid off while turning the steering wheel.

4) Add the specified fluid to reservoir tank at MAX level.

5) Continue to turn the steering wheel slowly from lock to lock until the bubbles stop appearing on oil surface while keeping the fluid at the level in the Step 4).

6) If turning the steering wheel in low fluid level condition, air will be sucked in pipe. In this case, leave it about half an hour and then do the step 5) again.

7) Start the engine and let it idle.

8) Continue to turn the steering wheel slowly from lock to lock again until the bubbles stop appearing on oil surface while keeping the fluid at the level in Step 4).

Normally bubbles stop appearing after three times turning of steering wheel from lock to lock.

9) In case bubbles do not stop appearing in the tank, leave it about half an hour and then do the step 4) all over again.

10) Lower the vehicle, and then idle the engine.

11) Continue to turn the steering wheel from lock to lock until the bubbles stop appearing and change of the fluid level is within 3 mm (0.12 in).

12) In case the following happens, leave it about half an hour and then do step 8) to 11) again.

(1) The fluid level changes over 3 mm (0.12 in).

(2) Bubbles remain on the upper surface of the fluid.

(3) Grinding noise is generated from oil pump.

13) Check the fluid leakage after turning steering wheel from lock to lock with engine running.

General Diagnostic Table

POWER ASSISTED SYSTEM (POWER STEERING)

12. General Diagnostic Table

A: INSPECTION

Trouble	Possible cause	Corrective action
<ul style="list-style-type: none"> • Heavy steering effort in all ranges • Heavy steering effort at stand still • Steering wheel surges when turning. 	1. Pulley belt <ul style="list-style-type: none"> • Unequal length of pulley belts • Adhesion of oil and grease • Loose or damage of pulley belt • Poor uniformity of pulley belt cross section • Pulley belt touches to pulley bottom • Poor revolution of pulleys except oil pump pulley • Poor revolution of oil pump pulley 	Adjust or replace.
	2. Tire and wheel <ul style="list-style-type: none"> • Improper tires out of specification*1 • Improper wheel out of specification*1 • Tires not properly inflated 	Replace or reinflate.
	3. Fluid <ul style="list-style-type: none"> • Low fluid level • Aeration • Dust mix • Deterioration of fluid • Poor warming-up of fluid *2 	Refill, bleed air, replace or instruct customer.
	4. Idle speed <ul style="list-style-type: none"> • Lower idle speed • Excessive drop of idle speed at start or at turning steering wheel *3 	Adjust or instruct customer.
	5. Measure hydraulic pressure. <Ref. to PS-80, INSPECTION, Oil Pump.>	Replace the problem parts.
	6. Measure steering effort. <Ref. to PS-88, MEASUREMENT OF STEERING EFFORT, INSPECTION, General Diagnostic Table.>	Adjust or replace.
<ul style="list-style-type: none"> • Vehicle leads to one side or the other • Poor return of steering wheel to center • Steering wheel surges when turning. 	1. Fluid line <ul style="list-style-type: none"> • Folded hose • Flattened pipe 	Correct or replace.
	2. Tire and wheel <ul style="list-style-type: none"> • Flat tire • Mix use of different tires • Mix use of different wheels • Abnormal wear of tire • Unbalance of remained grooves • Unbalance of tire pressure 	Adjust, fix or replace.
	3. Front alignment <ul style="list-style-type: none"> • Improper or unbalance caster • Improper or unbalance toe-in • Loose connection of suspension 	Adjust or retighten.
	4. Others <ul style="list-style-type: none"> • Damaged joint assembly • Unbalanced height • Unbalanced weight 	Replace, adjust or instruct customer.
	5. Measure steering effort. <Ref. to PS-88, MEASUREMENT OF STEERING EFFORT, INSPECTION, General Diagnostic Table.>	Adjust or replace.

*1 If the tires or wheels are wider than specifications, the load to power steering system is increased. Accordingly, in a condition, for example before fluid warms-up, relief valve may work before maximum turning angle. In this case, steering effort may be heavy. When the measured hydraulic pressure is normal, there is no abnormal thing.

*2 In cold weather, steering effort may be heavy due to increased flow resistance of cold fluid. After warming-up engine, turn the steering wheel from stop to stop several times to warm-up fluid. Then if steering effort reduces normally, there is no abnormal thing.

General Diagnostic Table

POWER ASSISTED SYSTEM (POWER STEERING)

*3 In cold weather or with insufficient warm-up of engine, steering effort may be heavy due to excessive drop of idling when turning steering wheel. In this case, it is recommended to start the vehicle with increasing engine speed than usual. Then if steering effort reduces normally, there is no abnormal thing.

1. NOISE AND VIBRATION

CAUTION:

Do not keep the relief valve operated over five seconds at any time or inner parts of the oil pump may be damaged due to rapid increase of fluid temperature.

NOTE:

- Grinding noise may be heard immediately after the engine start in extremely cold condition. In this case, if the noise goes off during warm-up there is no abnormal function in the system. This is due to the fluid characteristic in extremely cold condition.
- Oil pump makes whine or growl noise slightly due to its mechanism. Even if the noise can be heard when steering wheel is turned at stand still, there is no abnormal function in the system provided that the noise eliminates when the vehicle is running.
- When turning the steering wheel with service brake and/or parking brake applied, the noise is generated by creaking between disc and pads. However this does not indicate abnormal function in system.
- There may be a little vibration around the steering devices when turning steering wheel at standstill, even though the component parts are properly adjusted and have no defects.

Hydraulic systems are likely to generate this kind of vibration as well as working noise and fluid noise because of combined conditions, i.e., road surface and tire surface, engine speed and turning speed of steering wheel, fluid temperature and braking condition.

These phenomena do not indicate there are some abnormal functions in the system.

Confirm the vibration by turning the steering wheel repeatedly at various speeds from slow to rapid step by step with parking brake applied on concrete road and in "D" range for AT model.

Trouble	Possible cause	Corrective action
Hiss noise (continuous) While engine is running.	Relief valve emits operating sound when steering wheel is completely turned in either direction. (Do not keep this condition over five seconds.)	Normal Operation
	Relief valve emits operating sound when steering wheel is not turned. This means that the relief valve is defective.	Replace the oil pump.
Rattling noise (intermittent) While engine is running.	Interference with adjacent parts	Check the clearance. Correct if necessary. <Ref. to PS-69, INSPECTION, Pipe Assembly [LHD Model].>
	Loosened installation of oil pump, oil tank, pump bracket, gearbox or crossmember	Retighten.
	Loosened installation of oil pump pulley or other pulley(s)	Retighten.
	Loosened linkage or play of steering or suspension Loosened tightening of joint or steering column	Retighten or replace.
	Sound generates from the inside of gearbox or oil pump.	Replace the faulty parts of the gearbox or oil pump.
Knocking When turning steering wheel in both directions with small angle repeatedly at engine ON or OFF.	Excessive backlash Loosened lock nut for adjusting backlash	Adjust and retighten.
	Loosened tightening or play of tie-rod, tie-rod end	Retighten or replace.
Grinding noise (continuous) While engine is running.	Vane pump aeration	Inspect and retighten the fluid line connection. Refill the fluid and vent air.
	Vane pump seizing	Replace the oil pump.
	Pulley bearing seizing of oil pump	Replace the oil pump.
	Folded hose, flattened pipe	Replace.

General Diagnostic Table

POWER ASSISTED SYSTEM (POWER STEERING)

Trouble	Possible cause	Corrective action
Squeal, squeak (intermittent or continuous) While engine is running.	Maladjustment of pulley belt Damaged or charged pulley belt Unequal length of pulley belts	Adjust or replace. (Replace two belts as a set.)
	Runout or defacement of V-groove surface of oil pump pulley	Clean or replace.
Sizzling noise (continuous) While engine is running.	Fluid aeration	Fix the wrong part causing aeration. Replace the fluid and vent air.
	Damaged pipe of gearbox	Replace the pipe.
	Abnormal inside of hose or pipe Flattened hose or pipe	Rectify or replace.
	Abnormal inside of oil tank	Replace.
	Removed oil tank cap	Install cap.
Whistle (continuous) While engine is running.	Abnormal pipe of gearbox or abnormal inside of hose	Replace the faulty parts of the gearbox or hose.
Whine or growl (intermittent or continuous) While engine is running with/ without steering turned.	Loosened installation of oil pump, oil pump bracket	Retighten.
	Abnormal inside of oil pump, hose	Replace the oil pump or hose, if the noise can be heard when running as well as stand still.
	Torque converter growl, air conditioner compression growl	Remove the power steering pulley belt and confirm.
Grinding noise (continuous) While engine is running with the steering turned.	Abnormal inside of gearbox	Replace the faulty parts of gearbox.
	Abnormal bearing for steering shaft	Apply grease or replace.
	Generates when turning steering wheel with brake (service or parking) applied.	If the noise goes off when brake is released, it is normal.
Vibration While engine is running with/ without steering turned.	Too low engine speed	Adjust and instruct customers.
	Vane pump aeration	Fix the wrong part. Vent air.
	Damaged valve in oil pump, gearbox	Replace the oil pump, faulty parts of gearbox.
	Looseness of play of steering, suspension parts	Retighten.

General Diagnostic Table

POWER ASSISTED SYSTEM (POWER STEERING)

2. MEASUREMENT OF STEERING EFFORT

Step	Check	Yes	No
1 CHECK STEERING EFFORT. 1) Stop the vehicle on a concrete road. 2) Start the engine. 3) Run the engine at idle. 4) Install a spring scale on the steering wheel. 5) Pull the spring scale at a right angle to the steering wheel, and measure both right and left steering wheel efforts. NOTE: When turning the steering more quickly than necessary from a direction to the other direction at an engine speed over 2,000 rpm, steering effort may be heavy. This is caused by flow characteristic of oil pump and is not defective.	Is the steering effort less than 29.4 N (3.0 kgf, 6.6 lb)?	Go to step 2.	Adjust the backlash.
2 CHECK STEERING EFFORT. 1) Stop the engine. 2) Pull the spring scale at a right angle to the steering wheel, and measure both right and left steering wheel efforts.	Is the steering effort less than 294.2 N (30 kgf, 66.2 lb)?	Go to step 3.	Perform adjustment.
3 CHECK STEERING WHEEL EFFORT. 1) Remove the universal joint. 2) Measure steering wheel effort.	Is steering effort less than 2.26 N (0.23 kgf, 0.51 lb)?	Go to step 4.	Check, adjust and replace if necessary.
4 CHECK STEERING WHEEL EFFORT. Measure steering wheel effort.	Is the difference of steering effort between clockwise and counterclockwise less than 20%?	Go to step 5.	Check, adjust and replace if necessary.
5 CHECK UNIVERSAL JOINT. Measure the folding torque of the joint (yoke of steering column side). <Ref. to PS-21, INSPECTION, Universal Joint.>	Is the folding torque less than 7.3 N (0.74 kgf, 1.64 lb)?	Go to step 6.	Replace with a new one.
6 CHECK UNIVERSAL JOINT. Measure the folding torque of the joint (yoke of gearbox side). <Ref. to PS-21, INSPECTION, Universal Joint.>	Is the folding torque less than 3.8 N (0.39 kgf, 0.86 lb)?	Go to step 7.	Replace with a new one.
7 CHECK FRONT WHEEL. Check the front wheel.	If the front wheels have unsteady revolution or rattling and brake for dragging?	Inspect, readjust and replace if necessary.	Go to step 8.
8 CHECK TIE-ROD ENDS. Remove the tie-rod ends.	If the tie-rod ends of suspension have unsteady revolution or rattling?	Inspect and replace if necessary.	Go to step 9.
9 CHECK BALL JOINT. Remove the ball joint.	If the ball joints of suspension have unsteady revolution or rattling?	Inspect and replace if necessary.	Go to step 10.
10 CHECK GEARBOX. Measure the rotating of gearbox. <Ref. to PS-44, TURNING RESISTANCE OF GEARBOX, INSPECTION, Steering Gearbox [LHD Model].>	Is the rotating resistance of steering gearbox less than 10.5 N (1.1 kgf, 2.4 lb)? Is the difference between clockwise and counterclockwise less than 20%?	Go to step 11.	Readjust the backlash, and if ineffective, replace the faulty parts.
11 CHECK GEARBOX. Measure the sliding of gearbox. <Ref. to PS-43, SERVICE LIMIT, INSPECTION, Steering Gearbox [LHD Model].>	Is the sliding resistance of steering gearbox less than 314 N (32 kgf, 71 lb)? Is the difference between right and left sliding resistances less than 20%?	Steering effort is normal.	Readjust the backlash, and if ineffective, replace the faulty parts.

General Diagnostic Table

POWER ASSISTED SYSTEM (POWER STEERING)

3. INSPECTION OF CLEARANCE

This table lists various clearances that must be correctly adjusted to ensure the normal vehicle driving without interfering noise, or any other faults.

LOCATION	Minimum allowance mm (in)
(1) Crossmember-to-Hose ASSY	3 (0.12)
(2) Front exhaust pipe-to-Hose ASSY (Turbo model)	15 (0.59)
(3) Front frame side-to-Hose ASSY	10 (0.39)
(4) Turbo cover-to-Hose ASSY (Turbo model)	10 (0.39)
(5) Master cylinder-to-Return hose (Turbo model)	10 (0.39)
(6) Master cylinder-to-Hose clip (Model with vehicle dynamics control (VDC))	10 (0.39)
(7) VDC H/U-to-Hose ASSY (Model with vehicle dynamics control (VDC))	5 (0.20)
(8) Air cleaner-to-Hose ASSY (Turbo model)	5 (0.20)
(9) Air boot-to-Hose ASSY	10 (0.39)
(10) Protector-to-Hose ASSY (Turbo model, DOHC non-turbo model)	10 (0.39)
(11) Blow-by-to-Hose ASSY (Turbo model)	8 (0.31)
(12) Over flow hose-to-Hose ASSY (Turbo model)	8 (0.31)
(13) Brake pipe-to-Return hose (Model with ABS)	10 (0.39)
(14) Front suspension bracket-to-Return hose	5 (0.20)
(15) Front wheel apron-to-Return hose	5 (0.20)
(16) VDC H/U bracket-to-Suction hose (Model with vehicle dynamics control (VDC))	5 (0.20)
(17) Air cleaner case-to-Suction hose	5 (0.20)
(18) Air intake duct-to-Suction hose (Turbo model)	10 (0.39)
(19) Air duct-to-Suction hose (Turbo model)	10 (0.39)
(20) Front wheel apron-to-Reservoir tank	5 (0.20)
(21) VDC H/U-to-Reservoir tank (Model with vehicle dynamics control (VDC))	5 (0.20)
(22) Valve housing-to-DOJ (MT model)	12 (0.47)
(23) Valve housing-to-Crossmember (Hole)	1 (0.04)
(24) Bracket-to-Crossmember	1 (0.04)
(25) Cylinder-to-Crossmember	5 (0.20)
(26) Elbow-to-Crossmember	1 (0.04)
(27) Cylinder-to-Exhaust pipe	18 (0.71)
(28) Universal joint coupling-to-Turbo cover (Turbo model)	15 (0.59)
(29) Universal joint column side yoke-to-Master cylinder (Closest approach point when universal joint turns by 360°) (OUTBACK model)	5 (0.20)
(30) Cruise control-to-Hose ASSY (Model with cruise control)	10 (0.39)
(31) Universal joint coupling-to-ATF level gauge (LHD model)	10 (0.39)
(32) Boot-to-Exhaust pipe (LHD model)	18 (0.71)
(33) Return hose-to-Pressure hose	No contact between hoses

General Diagnostic Table

POWER ASSISTED SYSTEM (POWER STEERING)

- LHD model

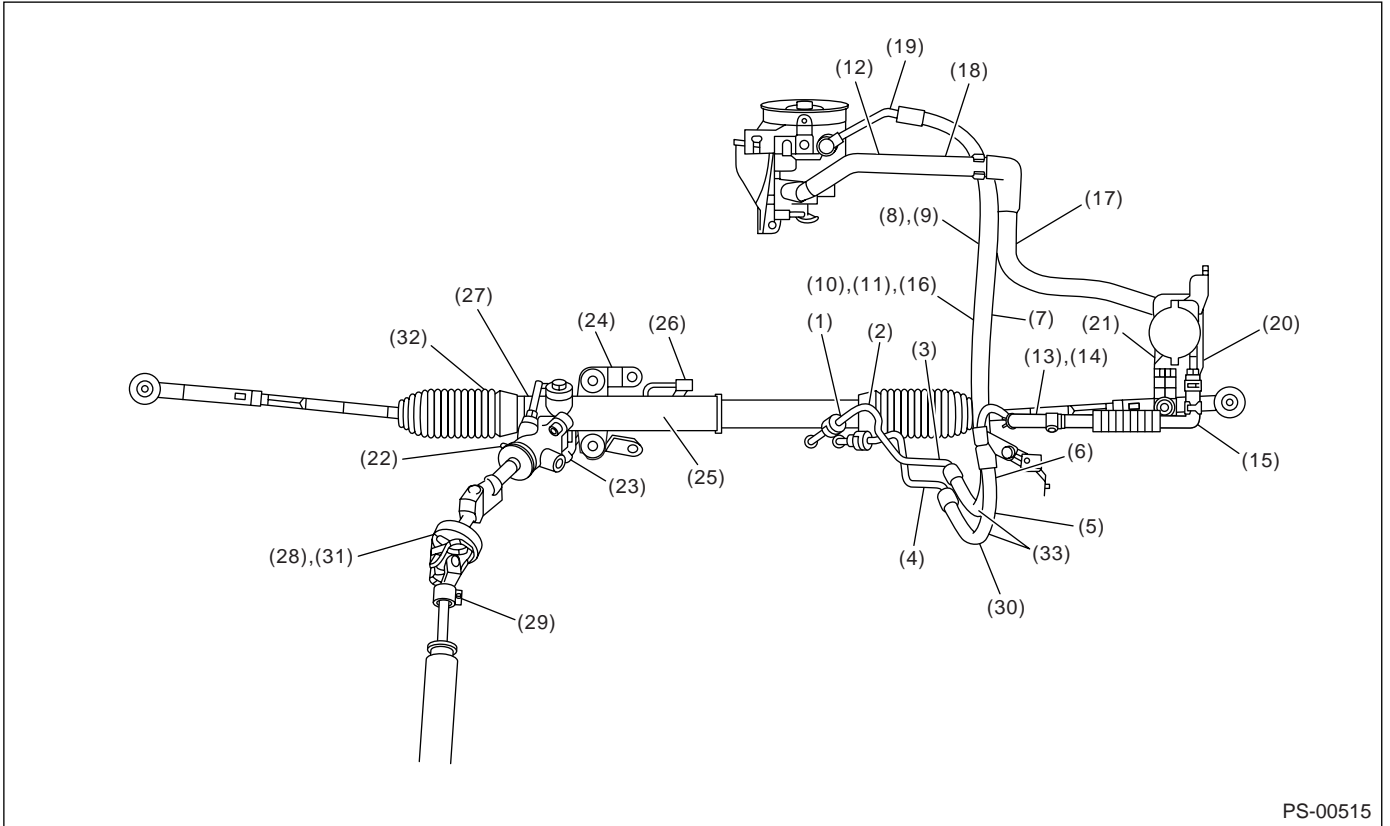

PS-00515

- RHD model

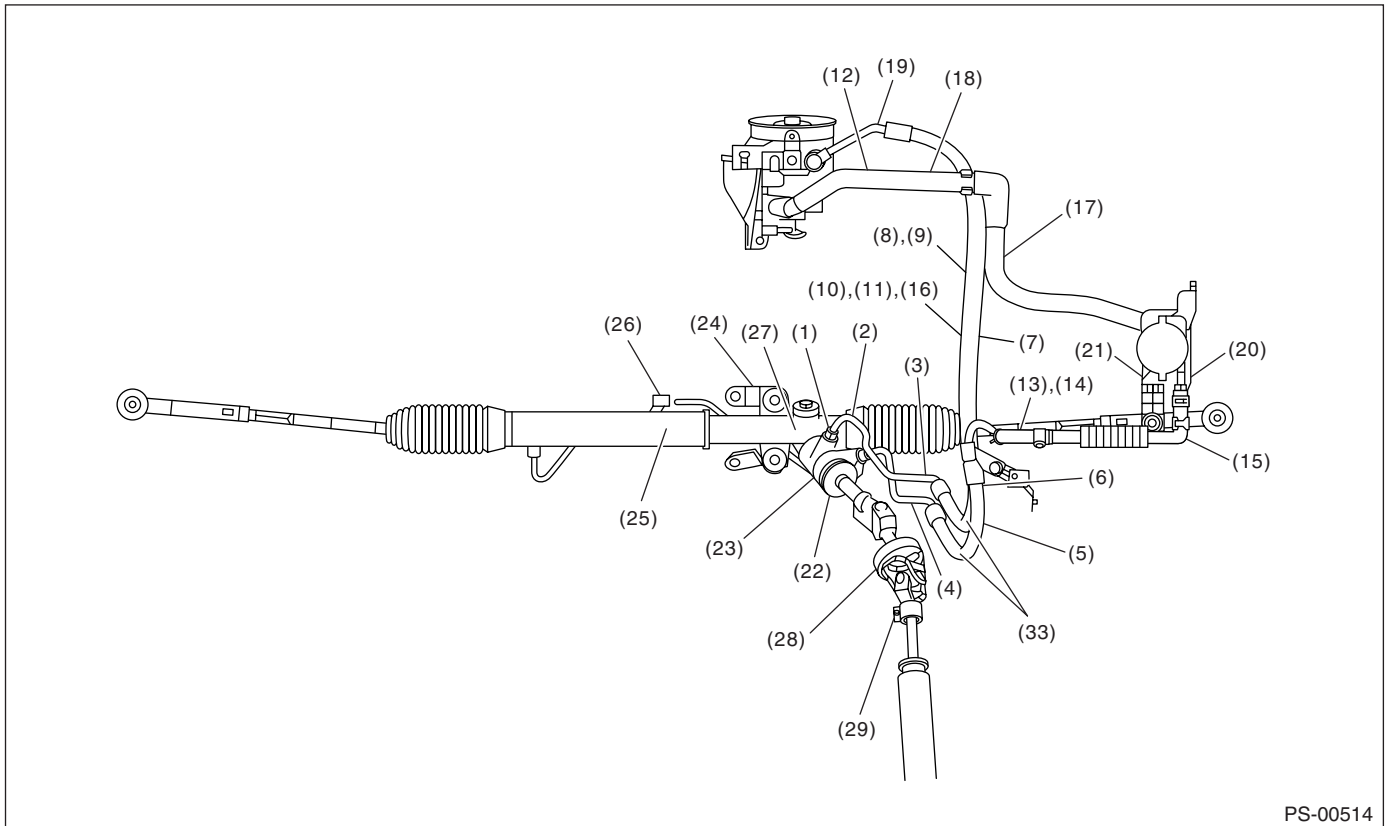

PS-00514